

Chapter 1: Keynote presentations

Authors:

Lital Alfonta

Doron Aurbach

Oleg Levin

Daniel Mandler

Vladimir Mirsky

Hubert Perrot

Laurent Ruhlmann

Theresa Schoetz

Martin Sjodin

Magdalena Skompska

Mikhail Vorotyntsev

Electrochemical properties of engineered biological nanowires

Yael Cohen, Lital Alfonta

Department of Life Sciences and Ilse Katz Institute for Nanoscale Science and Technology Ben-

*Gurion University of the
Negev, Beer-sheva, Israel
e-mail: alfonta@bgu.ac.il*

Microbial extracellular filaments, such as type IV pili, are typically non-conductive despite their structural versatility. In this work, we present a novel strategy to transform these protein assemblies into electrically conductive nanowires. Using genetic code expansion, we incorporated alkyne-containing non-canonical amino acids into the pili of *Pseudomonas aeruginosa*. This enabled precise, periodic functionalization of the filaments with azide-tagged redox-active proteins via bioorthogonal chemistry.

The resulting hybrid structures exhibit enhanced electrochemical properties, facilitating long-range electron transfer. High-resolution imaging using atomic force microscopy and cryo-electron microscopy confirmed the structural integrity and uniformity of the modified filaments. These engineered nanowires open new avenues for bioelectronic applications, including microbial electricity generation, biosensing, and bio-electrosynthesis.

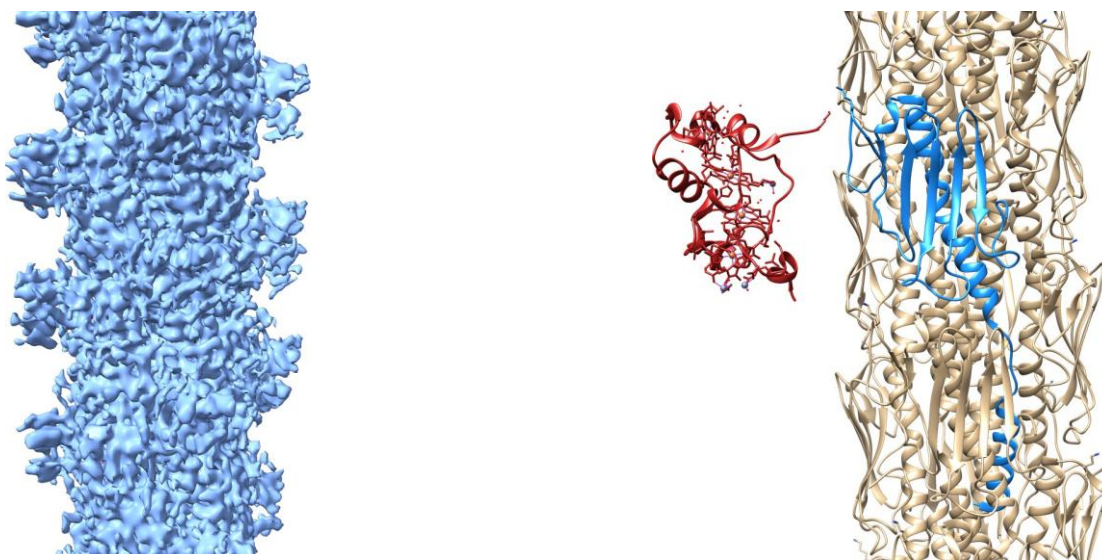

Left: Cryo EM image of engineered *Pseudomonas aeruginosa* (PAO1) pilin type IV “clicked” to short tetra heme cytochromes (STCs) 3.2 Å; Right: Three dimensional structures of STC and of PAO1 type IV pilin.

Guide for characterization of polymeric electrolytes in rechargeable solid-state Li and Na batteries

Doron Aurbach

Bar-Ilan University, Ramat Gan, Israel
e-mail: Doron.Aurbach@biu.ac.il

Solid polymer electrolytes (SPEs), particularly those based on polyethylene oxide (PEO), are key enablers for the development of safe and high-performance all-solid-state batteries (ASSBs) for Li and Na systems. Despite extensive research, a unified methodology for extracting meaningful electrochemical and physicochemical parameters from SPE-based systems remains lacking.

In our presentation, we are sharing a comprehensive experimental framework for the characterization of polymer electrolytes and their interfaces with active metal electrodes in solid-state batteries, with emphasis on electrochemical impedance spectroscopy (EIS) as a central and versatile analytical tool.

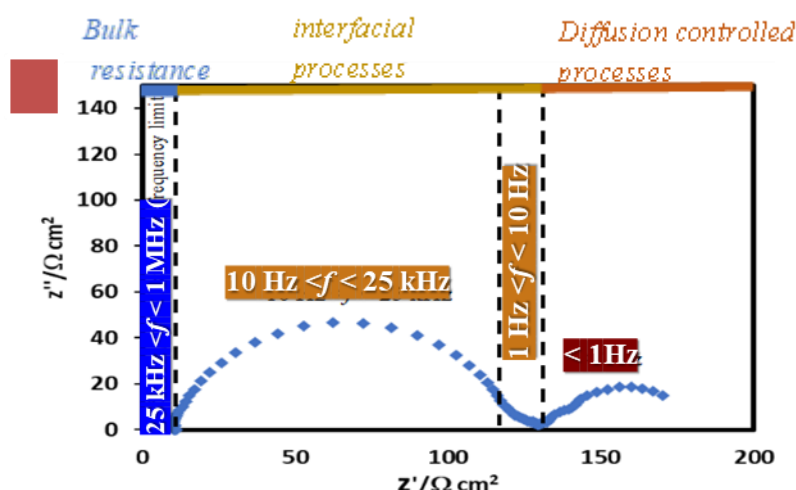

Figure 1. Representative Nyquist plot illustrating separation between bulk resistance, interfacial processes, and diffusion-controlled behavior

The study integrates bulk and interfacial analysis, demonstrating that while intrinsic properties such as ionic conductivity, activation energy, cation transference number, and salt diffusion coefficients are essential, the overall battery performance is often governed by the electrode–electrolyte interfaces (Fig. 1).

A special emphasis is focused on the interpretation of impedance spectra across frequency domains, enabling identification of bulk, interfacial, and diffusion-controlled processes. Time-related impedance spectroscopy (TRIS) and cycling-related impedance spectroscopy (CRIS) are introduced as powerful tools for tracking interfaces characteristics' evolution under static and dynamic conditions.

The methodology is illustrated through case studies including salt effects (Figure 2), electrolyte membranes preparation, and a judicious use of ceramic additives (TiO₂, LATP, zeolites), showing that performance improvements arise mainly from interfacial modifications rather than bulk changes (Figure 3).

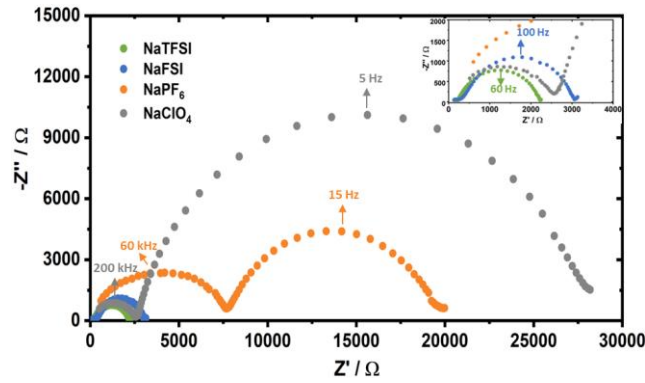

Figure 2. Nyquist representations of Na/SPE/NVP cells comprising SPE with different salts, at 40°C

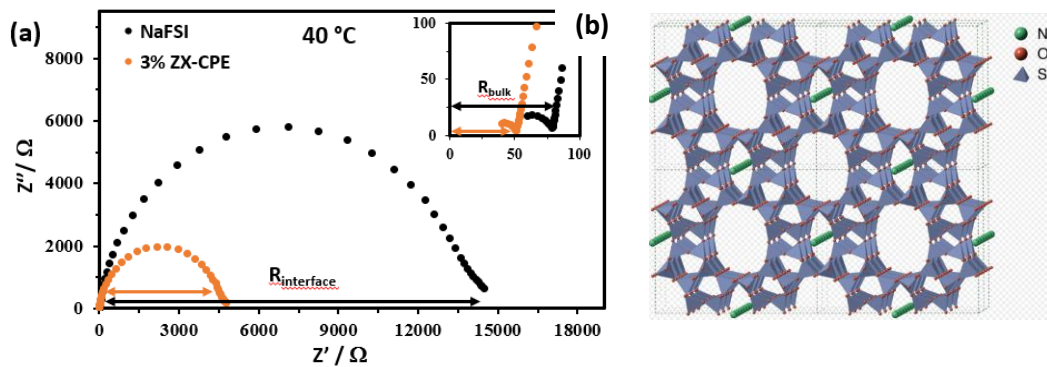

Figure 3: (a) Nyquist plots of Na/PEO:NaFSI/Na symmetric cells with and without Zeolite, (b) Zeolite structure

Advanced methods such as impedance spectroscopy at potential steps (ISPS) and distribution of relaxation times (DRT) enable separation of overlapping processes such as charge transfer and surface films' resistance (Figure 4).

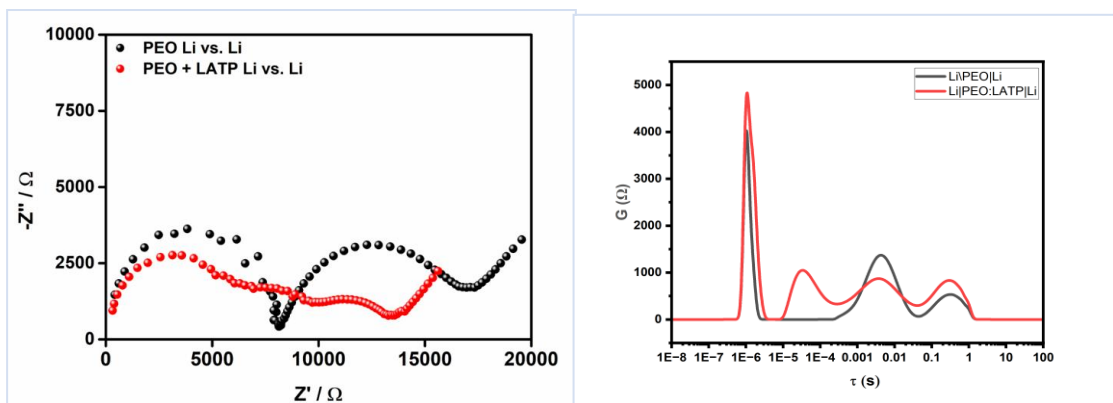

Figure 4. Nyquist plot and its Distribution of relaxation times (DRT) for Li/PEO/Li and Li/PEO+LATP/Li cells

In addition, the presentation will demonstrate solid-state batteries characterization methodologies through fundamental studies, combined with state-of-the-art results obtained in our laboratory (Figure 5), bridging fundamental understanding with cutting-edge materials performance.

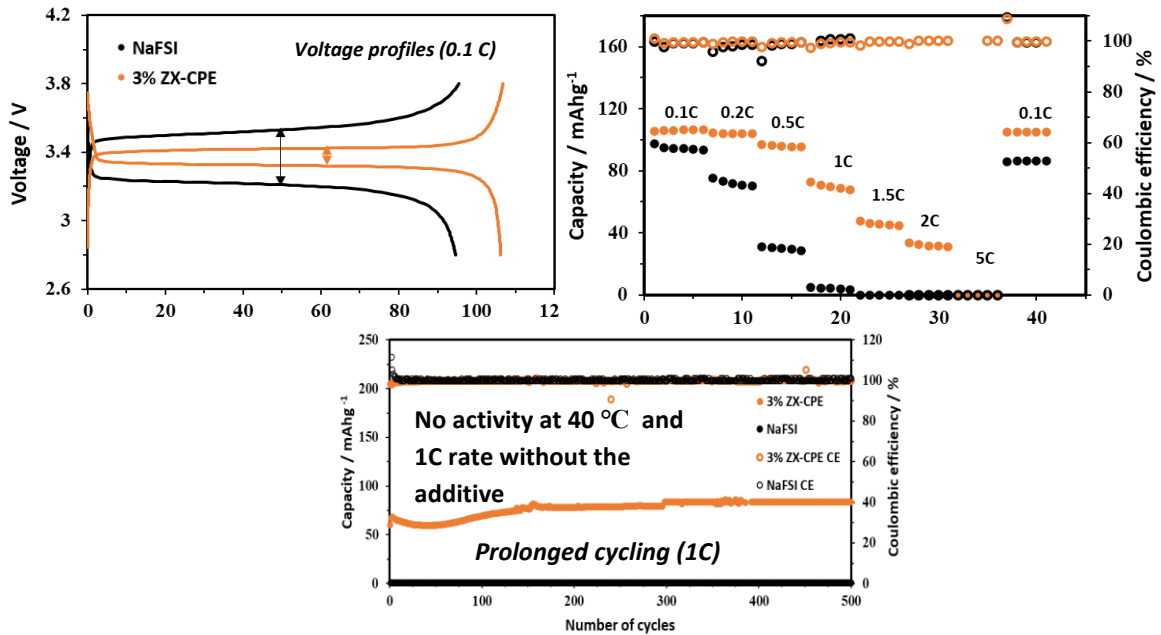

Figure 5: Influence of zeolite additive on Na|PEO:NaFSI|NVP all-solid-state-batteries: electrochemical performances at 40 °C

Acknowledgments: Partial financial support was provided by the Israel Science Foundation (ISF) and the U.S.-Israel Binational Industrial Research and Development (BIRD) Foundation. Support by INIES, the Ministry of Energy and Infrastructure, and BINA is gratefully acknowledged

[1] M. Fayena-Greenstein et al., Solid State Ionics, **2025**, 430, 116989-117005.

[2] N. R. Samala et al., Chemical Engineering Journal, **2025**, 511, 162070–162080

Regulating the Conductivity Window of Potentioresistive Materials for Lithium-Ion Battery Protection

Oleg Levin

*St. Petersburg State University, Institute of Chemistry, 199034, St. Petersburg, Russia
o.levin@spbu.ru*

Materials capable of altering their properties in response to an external stimulus play an important role in the functionality of numerous sensing and actuating mechanisms. Within the domain of lithium-ion batteries (LIBs), materials exhibiting variable conductivity are particularly significant in mitigating hazards associated with overcharging or short circuits, thereby averting potential battery overheating and explosions. Recently, the authors of this study have proposed a promising strategy for safeguarding LIBs, leveraging conjugated conductive polymers that transition from a conductive to a non-conductive state upon reaching critical electrode potential thresholds.

Central to the efficacy of these materials in providing protection is their characteristic bell-shaped conductivity profile in response to applied potential, a phenomenon termed "potentioresistivity" by the authors, drawing an analogy with "thermoresistivity". Presently, the practical implementation of potentioresistive protection is constrained by the limited conductivity range of existing conducting polymers. Nonetheless, it is theoretically feasible to modulate the conductivity window of potentioresistive materials, offering the prospect of tailoring materials to correspond with diverse LIB configurations.

This report explores the feasibility of engineering potentioresistive materials with predefined conductivity window parameters through the formulation of composites comprising conducting polymers and redox additives. The compositional makeup of these composites holds sway over the characteristics of the conductivity window. Manipulating composite composition allows for the synthesis of materials exhibiting controlled potential ranges and amplitude of conductivity alteration, thus rendering them suitable for incorporation as protective layers within battery systems and other pertinent devices.

Acknowledgments: This work was supported by the Russian Science Foundation, grant No. 24-13-00204

Nanoparticle-Imprinted Matrices: A New World of Nanoconfinement

Din Zelikovich, Pavel Savchenko, Hila Sagi, Noa Casper and Daniel Mandler

Institute of Chemistry, the Hebrew University of Jerusalem, Jerusalem 9190401, Israel
e-mail: daniel.mandler@mail.huji.ac.il

This contribution deals with a new area developed by us, which uses imprinted nanoparticles (NPs) for creating well-defined nanocavities. The approach is termed nanoparticle-imprinted matrices (NAIM) and the results have opened many possibilities spanning from the very selective detection of NPs to the formation of very precise nanocavities (Figure 1) and studying a variety of reactions, such as electrochemical deposition and electropolymerization inside [1-6]. The presentation will therefore discuss and show how NPs can be detected very selectively, opening the concept of NP speciation, and then, we will delve into the use of the nanocavities for nanoconfined electrochemistry.

More specifically, we have shown that the imprinting of NPs is based on both physical and chemical matching between the NP and the matrix. Accordingly, we were able to reuptake very selectively NPs having the same metal core; however, distinguished by their capping agents. We will show that we can tune the matrix to better recognize the NPs, and recognition can also be carried out for NPs in the air.

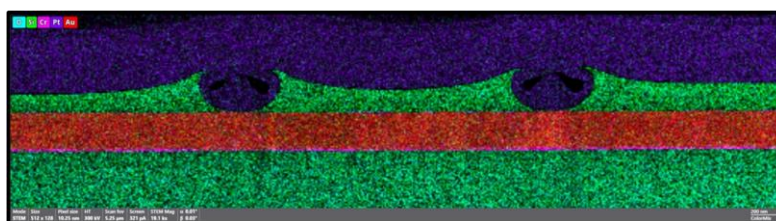

Figure 1: Nanocavities formed by the NAIM approach.

More recently, we have developed a generic approach for significantly enhancing the sensitivity of detection by coupling chemical amplification with dual selectivity. Gold NPs were functionalized with a molecular recognition unit, i.e., mercaptophenylboronic acid, that undergoes a significant structural change upon analyte, i.e., dopamine (DA) binding (Figure 2). These functionalized nanoparticles were imprinted in a thin film made by electropolymerization of aryldiazonium precursors. Subsequent removal of the nanoparticles generates nanocavities that were complementary in shape and surface chemistry to the analyte-bound functionalized NPs, allowing selective reuptake only of the nanoparticles carrying the target molecule. Therefore, the oxidation of these reuptaken metallic nanoparticles provided a highly amplified electrochemical signal, directly correlated to the analyte concentration.

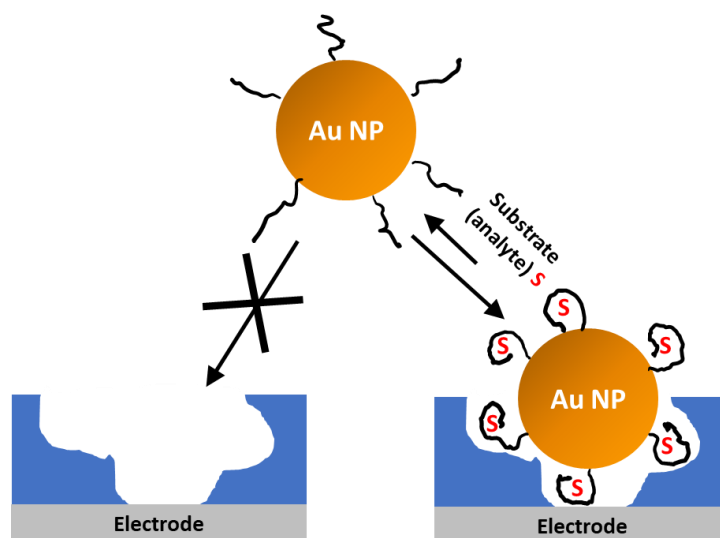

Figure 2: Schematics of the NAIM approach for increasing the sensitivity in the detection of different analytes.

Hence, to summarize, the NAIM approach can be used for a wide range of exciting applications and there is room for additional players and ideas.

Acknowledgments: The Israel Science Foundation (grants No. 1953/22) and the BSF-NSF (grant No. 2023758) are acknowledged.

- (1) Sagi-Cohen, H.; Savchenko, P.; Mandler, D. Studying the Ingress of Ag Nanoparticles into Imprinted Nanocavities by Nanoimpact Electrochemistry. *ChemElectroChem* 2025, 7.
- (2) Savchenko, P.; Zelikovich, D.; Sinai, H. E.; Baer, R.; Mandler, D. The Effect of the Capping Agents of Nanoparticles on Their Redox Potential. *J. Am. Chem. Soc.* 2024, 146, 22208-22219.
- (3) Sagi-Cohen, H.; Savchenko, P.; Mandler, D. Selective detection of nanomaterials: Gold nanorod imprinted matrices. *Sens. Actuator B-Chem.* 2024, 410, 7.
- (4) Zelikovich, D.; Savchenko, P.; Mandler, D. High Recognition of Isomer-Stabilized Gold Nanoparticles through Matrix Imprinting. *ACS Appl. Mater. Interfaces* 2023, 15, 32687-32696.
- (5) Zelikovich, D.; Dery, L.; Sagi-Cohen, H.; Mandler, D. Imprinting of nanoparticles in thin films: Quo Vadis? *Chem. Sci.* 2023, 14, 22.
- (6) Zelikovich, D.; Dery, S.; Bruchiel-Spanier, N.; Tal, N.; Savchenko, P.; Gross, E.; Mandler, D. Shell-Matrix Interaction in Nanoparticle-Imprinted Matrices: Implications for Selective Nanoparticle Detection and Separation. *ACS Appl. Nano Mater.* 2021, 4, 10819-10827.

Cyclic voltarefractometry of individual nanoparticles

Shavkat Nizamov, Veronika Laurinavichyute, Vladimir M. Mirsky

*Brandenburg University of Technologies Cottbus – Senftenberg, 01968 Senftenberg, Germany
e-mail: mirsky@b-tu.de*

The permanent growth of nanoparticle production requires a highly sensitive analytical method to quantify and identify these potentially hazardous materials. Recently, wide-field surface plasmon resonance microscopy (WF-SPRM) was proposed as a solution to this problem. This approach enables real-time detection of the interaction between individual nanoparticles and the sensor surface. The volume concentration is characterized by the number of nanoparticle-surface binding events per time and surface area. The large surface area of the sensor allows one to detect hundreds of events in each frame, or up to a million particles on the surface. Stable analysis of nanoparticles in complex environments such as fruit juice, wine, and cosmetics has been achieved. The linear dependence between image intensity and particle size enables the creation of histograms of particle size distribution. This approach can be used for technical (e.g., polymeric or inorganic) or biological (e.g., viruses, liposomes, or extracellular vesicles) nanoparticles. However, the absence of equilibrium, which is typical for the adsorption of large analytes, complicates the application of classical receptor-based affinity sensing approaches to identify nanoparticles.

To determine chemical composition of single nanoparticles separately, the WF-SPRM can be used as a tandem technique, for example, in combination with electrochemistry: electrochemical conversions lead to the change in the particle refractive index or their dissolution [3] while the value of the applied potential of this conversion characterizes the material of the particular nanoparticle. This novel optoelectrochemical approach designed as voltarefractometry, is performed simultaneously but independently for each adsorbed particle. The same approach allows also monitoring of electrochemical deposition of metals with formation of nanoparticles [4]. Using of organic electrolytes in the combination of WF-SPRM and electrochemistry allows one to extend the range of applied potentials and to study materials that do not demonstrate electrochemical activity in aqueous conditions. For instance, the approach was applied in acetonitrile-based electrolyte for analysis of nanoparticles from titanium dioxide (nanoparticles from anatase and rutile were distinguished) [5] or for identification of lithium iron phosphate nanoparticles.

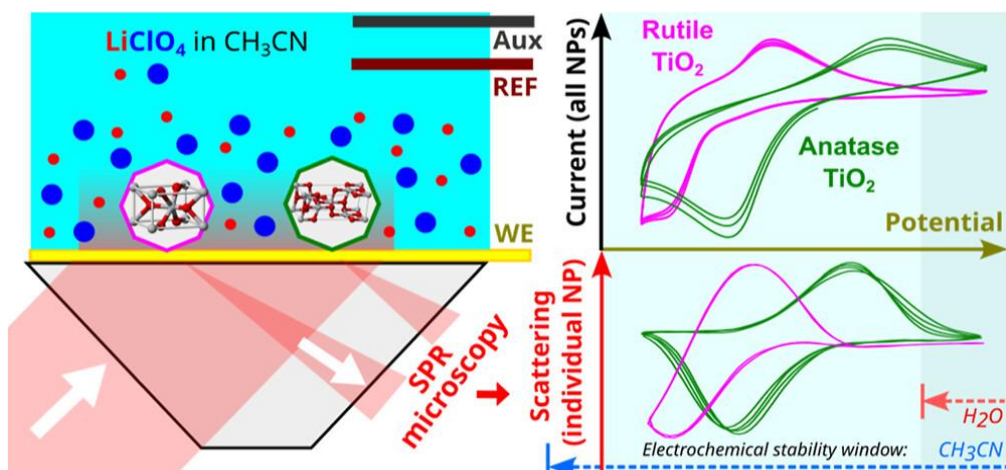

Fig. 1. Cyclic voltarefractometry detects electrochemically modulated changes in the refractive index of individual nanoparticles during potential cycling.

- [1] S. Nizamov, S. D. Sazdovska, V. M. Mirsky. *Anal. Chim. Acta* 2022, 1204, 339633.
- [2] S. Nizamov, V. Scherbahn, V.M. Mirsky. *Anal. Chem.*, 88, 10206-10214, (2016).
- [3] S. Nizamov, O. Kasian, V. M. Mirsky. *Angew. Chem., Int. Ed.* 2016, 55, 7247.
- [4] V. K. Laurinavichyute, S. Nizamov, V. M. Mirsky. *Electrochim. Acta*, 2021, 382, 138278.
- [5] V. K. Laurinavichyute, S. Nizamov, V. M. Mirsky. *Anal. Chem.*, 2025, 97, 1160.

Deep Investigation of Various Electrified Interfaces Through Advanced Electrogravimetric Sensors

J. Su¹, C. Debiemme-Chouvy¹, A. Pailleret¹, L. Fillaud¹ and H. Perrot¹

¹ Sorbonne Université-CNRS, Laboratoire Interfaces et Systèmes Electrochimiques, Paris, France
e-mail: hubert.perrot@sorbonne-universite.fr

One of the greatest challenges of our century will be to replace fossil fuels with more environmentally friendly energies. To achieve this, academic research must develop innovative devices, particularly in the field of electrochemical energy storage and conversion. While many different materials have been developed for this purpose, advanced characterization methods are less well developed. While the vast majority are based on electrochemical techniques, other tools have been developed, notably using gravimetric sensors based on quartz crystal microbalances. These are highly sensitive and, when coupled with electrochemistry, can be used to quantify the species incorporated into a battery or supercapacitor material. More recently, unprecedented coupling with electrochemical impedance measurements has allowed very detailed investigations to characterise the species involved in charge compensation processes. The principle of this technique called *ac*-EQCM or *ac*-electrogravimetry is presented in Figure 1. Two experimental key transfer functions can be measured for different polarization values, $DE/DI(w)$ and $Dm/DE(w)$.

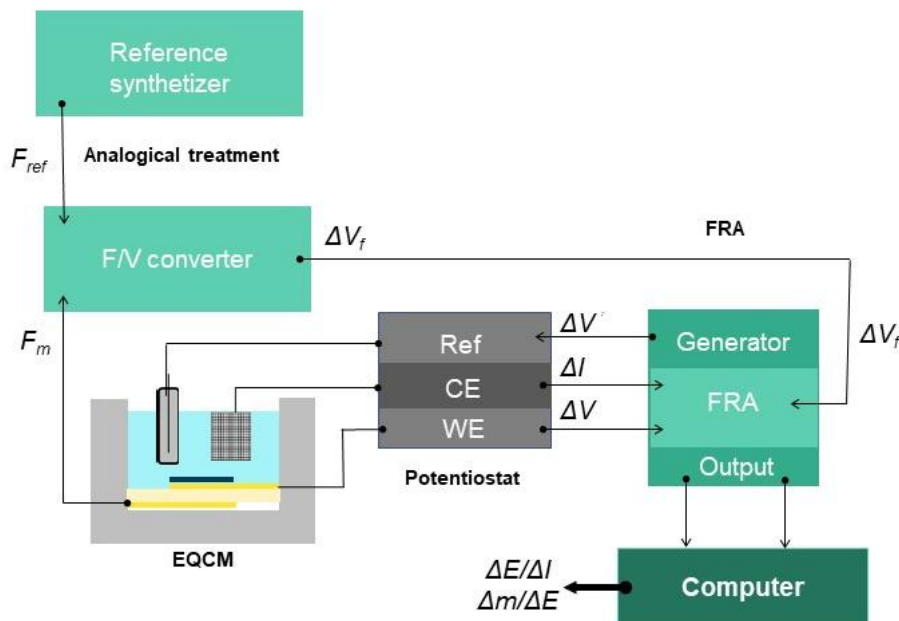

Figure 1: *ac*-EQCM equipment with the two main transfer functions which can be obtained, $DE/DI(w)$ and $Dm/DE(w)$. [1]

Using different models, it is possible to identify the ions/free solvents that are transferred to the electrode/electrolyte interface and to determine the associated key parameters such as transfer rates/resistances. This coupling between electrochemistry and gravimetry should lead to a better understanding of the complex mechanisms occurring in these devices and thus, improve their performance. Some selected and pertinent examples will be given here as various materials/electrolytes can be explored through these tools. Indeed, it starts from carbonaceous films [2], to metal oxide [3] or conducting polymers [4], materials which can be used for aqueous batteries or supercapacitors. One of the common and main result is focused on the impact of the solvent which can be associated to the various ions or alone during the various electrochemical reactions. Here, an example is given, where we explore the development of multi-wall carbon nanotubes (MWCNTs) electrodes for supercapacitors by replacing conventional non-conductive polymer binders, such as poly(vinylidene fluoride-co-hexafluoropropylene) (PVDF-HFP) by a conductive polymer, poly(3,4-ethylenedioxythiophene) (PEDOT).

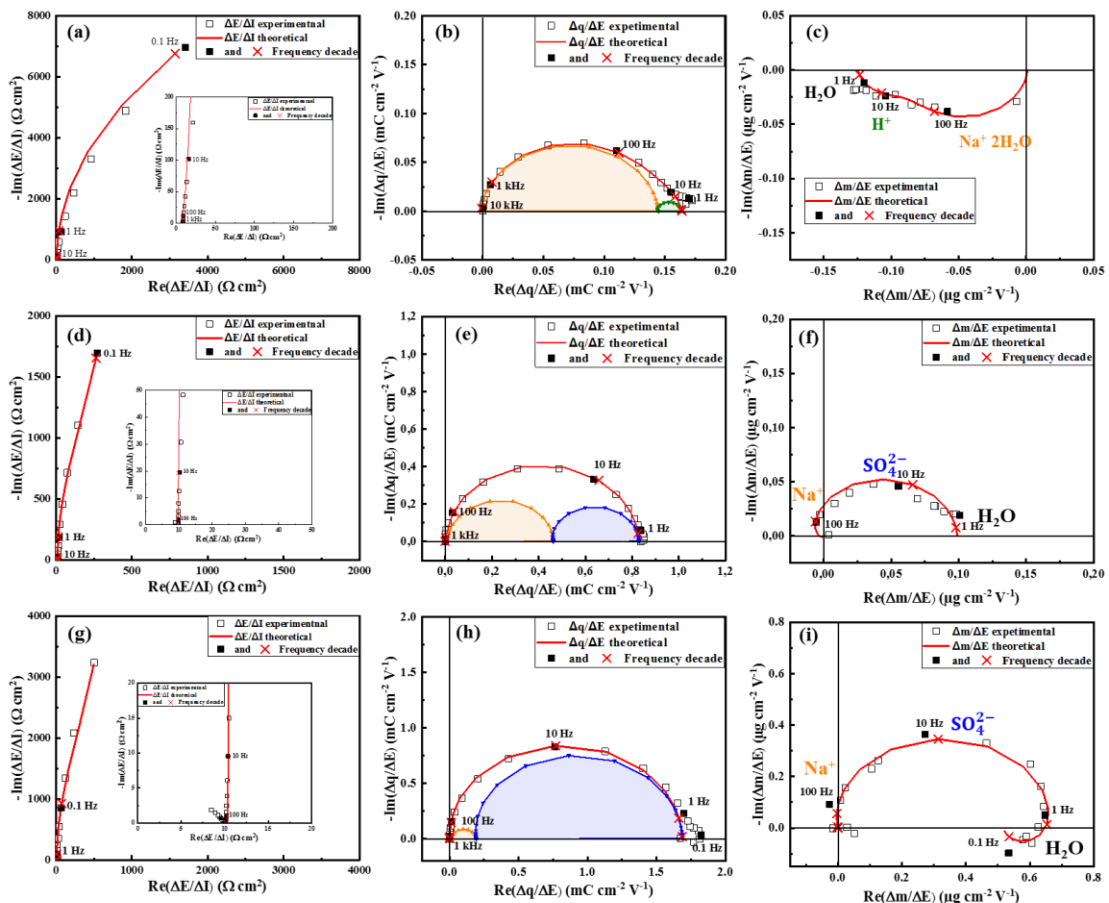

Figure 2: Experimental and theoretical *ac*-electrogravimetric data of MWCNTs/PVDF-HFP (a-c), PEDOT (d-f) and PEDOT/MWCNTs (g-i) at -0.5 V vs. Hg/Hg₂SO₄, in which (a), (d) and (g) are $DE/DI(w)$; (b), (e) and (h) are $Dq/DE(w)$; (c), (f) and (i) are $Dm/DE(w)$ [4].

Results of *ac*-EQCM are presented in Figure 2 with the different transfer functions, experimental and fitted. *ac*-electrogravimetry, have been employed to investigate the charge storage mechanisms and ionic transfer kinetics of the prepared thin films. In Na₂SO₄ electrolyte, the mass variation during the cyclic voltammetry measurements suggests anions dominate the contribution to the charge compensation process in PEDOT/MWCNTs. *Ac*-electrogravimetry provides the first insight that the synergistic effect between MWCNTs and PEDOT leads to higher concentration of ionic species in the film.

- [1] C. Keller, A. Belime, L. Bernard, Q. Berrod, Y. Kervella, L. Picard, S. Lyonnard, O. Sel and H. Perrot, in press *ACS Applied Materials & Interfaces*.
- [2] C. Keller, C. Debiemme-Chouvy, G. Barbillon, O. Sel, H. Perrot, *Carbon*, **2024**, 227, 119246.
- [3] W. Gao, N. Krins, C. Laberty-Robert, H. Perrot et O. Sel, *Electrochimica Acta*, **2022**, 413, 140171.
- [4] J. Su, T. Petenzi, G. Barbillon, C. Debiemme-Chouvy, L. Fillaud, A. Pailleret, H. Perrot, *Nano Select*, **2025**, e70077.

PHOTOREDOX AND PHOTO(ELECTRO)SWITCHABLE MATERIALS BASED ON PORPHYRIN

L. Ruhlmann¹

¹Université de Strasbourg, Institut de Chimie de Strasbourg, UMR 7177, 4 rue Blaise Pascal, 67000, Strasbourg, France. e-mail: lruhlmann@unistra.fr

An original method of electropolymerization of porphyrin based on nucleophilic attack onto the electrogenerated porphyrin radical cation or dications by nucleophile such as Py-R-Py (Py = pyridine) or di(phenylphosphane) has been developed giving 1D or 2D material (Fig. 1a) [1]. Using the same methodology, the synthesis of a diarylethene-(iso)porphyrin photoswitchable copolymer has been developed (Fig. 1b) where the incorporated diarylethene maintains its reversible photochromism upon the UV or Visible radiation with ring-opening and closing [2].

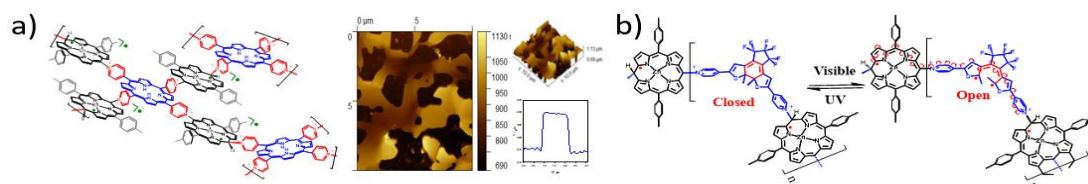

Fig. 1 a) 2D-copolymer and b) photo(electro)switchable copolymer studied.

The development of hybrid materials incorporating polyoxometalates (POMs) to elaborate new functional materials has been also conducted using this electropolymerization strategy (Fig. 2a and 2c, Film I). [3-5] A second methodology is also proposed to form hybrid POM-porphyrin films: first the formation of cationic polyporphyrin electropolymer. Then, by metathesis reaction, the exchange onto the surface of the initial counter ions by the POM^{n-} (Fig. 2c, Film II) [6] or by the nanoparticles stabilized with POM^{n-} (Fig. 2c, Film III) [7].

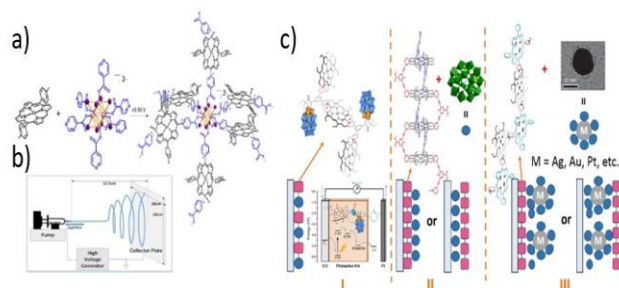

Fig. 2. a) 3D poly-isoporphyrin-PIM copolymer (PIM = PolyiodoMetalate). b) Electrospinning configuration used for deposition of ITO nanofiber layers. c) Various type of porphyrin-POM films.

The photovoltaic performances of these hybrid materials have been investigated given by now good efficiency. In order to increase the efficiency, mesoporous ITO electrodes have been also used (Fig. 2b).

- [1] a) L. Ruhlmann, J.-H. Fuhrhop, *J. Am. Chem. Soc.*, **1999**, *121*, 6664. b) Z. Huo, V. Badets, L. Ruhlmann, *Eur. J. Org. Chem.* **2021**, 6636. [2] a) M. Boudiaf, L. Ruhlmann et al, *Electrochimica Acta*, **2019**, *309*, 432. b) Y. Liang, L. Ruhlmann et al, *Molecules*, **2024**, *29*(13), 3056. [3] Z. Huo, S. Yang, G. Izzet, A. Proust, L. Ruhlmann et al *Electrochimica Acta*, **2021**, *368*, 137635. [4] Z. Huo, L. Ruhlmann et al, *Inorg. Chem.* **2025**, *64*, 7, 3371–3383. [5] Y. Liang, M. N. Sokolov, L. Ruhlmann et al, *Electrochimica Acta*, **2021**, *388*, 138493. [6] Z. Huo, SG. Izzet, A. Proust, L. Ruhlmann *Electrochimica Acta*, **2021**, *368*, 137635. [7] Z. Huo, Y. Liang, L. Ruhlmann et al, *Chem. Comm.* **2021**, *57*, 1482-1485.

Electrochemical Interface Engineering for Mechanistic Insights into Charge Storage

T. Schoetz¹, P. Ghasemianhangarani¹, R. Chow¹, L.W. Gordon²

¹ Chemical and Biomolecular Engineering, University of Illinois Urbana-Champaign,
Urbana, IL 61801, USA.

² Department of Chemistry, Technical University of Denmark, 2800 Kgs. Lyngby, Denmark
e-mail: schoetz@illinois.edu

Researchers developing the next generation of energy storage systems are challenged to understand and analyze the different charge storage mechanisms, subsequently, use this understanding to design and control materials and devices that bridge the gap between high specific energy and power at a target cycle life. Correctly identifying and quantifying the prominent charge storage mechanism, which is either faradaic diffusion-limited, faradaic non-diffusion-limited (or pseudocapacitive), or capacitive, is of the utmost importance for understanding how the system functions and tuning material properties for specific applications. The different charge storage mechanisms are defined by a characteristic current-time relationship, that has been expressed for faradaic diffusion-limited (Cottrell equation) and true capacitive charge storage. However, the characteristic current-time relationship for pseudocapacitive charge storage remains unelucidated despite to date many energy storage devices, particularly those having ionic liquids, deep eutectic solvents or highly concentrated electrolytes, exhibit electrochemical interfaces with this mechanism. This talk presents the work on a theoretical framework¹ for pseudocapacitive charge storage taking into consideration the faradaic nature of this mechanism and deviation from the classic electrochemical interface structure, which is the root cause for pseudocapacitance². The theory will be corroborated with experimental current-time relationships using conventional variable-rate cyclic voltammetry. The results shed light on interfacial kinetics and mass transport processes in lithium-ion batteries with organic electrolytes and multivalent batteries with ionic liquids. The insights inform electrode and electrolyte material fabrication, e.g., for fast-charging³ and low-temperature batteries⁴.

[1] P. Ghasemianhangarani, G. Farhan, D. del Mundo, T. Schoetz, *Advanced Energy Materials*, **2025**, 15, 2404704.

[2] T. Schoetz, L.W. Gordon, S. Ivanov, A. Bund, D. Mandler, R.J. Messinger, *Electrochimica Acta*, **2022**, 412, 140072.

[3] J.H. Xu, T. Schoetz, J.R. McManus, V.R. Subramanian, P.W. Fields, R.J. Messinger, *Journal of The Electrochemical Society*, **2021**, 168, 060514.

[4] T. Schoetz, J.H. Xu, R.J. Messinger, *ACS Applied Energy Materials*, **2023**, 6, 2845-2854.

Immobilization Strategies for Molecular Iron Catalysts: Linking Molecular Electrochemistry to Carbon Electrodes

Philipp Gaiser¹, Rikard Emanuelsson², Doriand Jollec¹, Lucas Potet¹, Maria Strømme¹, and Martin Sjödin¹

¹*Department of Materials Science and Engineering, Division of Nanotechnology and Functional Materials, Uppsala University, Box 35, SE-751 03 Uppsala, Sweden*

²*Department of Chemistry - BMC, Organic Chemistry, Uppsala University, Box 576, SE-751 23 Uppsala, Sweden*

e-mail: martin.sjodin@angstrom.uu.se

Immobilization of molecular electrocatalysts on electrode surfaces is a key strategy to combine the well-defined reactivity of molecular catalysts with the robustness and scalability of heterogeneous systems. However, the immobilization approach strongly influences the redox properties and ultimately the catalytic performance of the molecular active site.

Here, we investigate and compare different immobilization strategies for a non-heme iron-based molecular catalyst of the α -[Fe(mcp)L₂] family, used as a model system. In solution, the intrinsic electrochemical properties of the iron complex are established through detailed characterization, revealing a pronounced sensitivity of the Fe(II)/Fe(III) redox couple to ligand identity, electrolyte anions, and proton activity. [1] These findings highlight the importance of ion coordination and proton-coupled electron transfer in governing the redox behavior of the catalyst.

Building on this understanding, the complex is immobilized onto electrode surfaces using two different approaches. First, conducting redox polymers are employed as an immobilization platform, where the iron complex is incorporated as a pendant group within a conductive polymer backbone. In-situ electrochemical and spectro-electrochemical studies demonstrate efficient electronic communication between the electrode and the immobilized catalyst, while preserving key molecular redox characteristics. [2] Second, ongoing work explores direct binding of the iron complex to carbon-based electrodes via covalent grafting strategies, aiming to achieve well-defined surface coverages without a polymeric mediator.

Together, these studies provide a comparative framework for understanding how different immobilization strategies affect the electrochemical behavior of molecular iron catalysts, offering design guidelines for heterogeneous molecular electrocatalysts.

[1] P. Gaiser, R. Emanuelsson, M. Strømme, M. Sjödin, *Electrochim. Acta*, **2025**, 519, 145759.

[2] P. Gaiser, D. Jollec, R. Emanuelsson, M. Strømme, M. Sjödin, *ACS Electrochemistry*, **2026**, 2 (3), 752-764.

Visible Light-driven Z-scheme BiVO₄/Au/g-C₃N₄ Photocatalyst – Synthesis, Properties and Applications

Ewelina Wierzyńska, Tomasz Łęcki, Kamila Zarębska, Magdalena Skompska,

University of Warsaw, Faculty of Chemistry, Pasteur 1, 02-093 Warsaw, Poland...

e-mail: m.skompska@uw.edu.pl

Photocatalysis based on hybrid semiconductor systems shows great promise in environmental remediation, due to the possibility of generating reactive superoxide anion radicals ($\cdot\text{O}_2^-$) and hydroxyl radicals ($\cdot\text{OH}$) under solar radiation. These radicals can be involved in breaking chemical bonds and transformation of organic pollutants (pharmaceuticals, dyes, pesticides, etc.) into simpler and less toxic compounds. Photocatalytic materials have progressed from single-component semiconductors, limited by rapid photocarrier recombination, through type II, to inspired by natural photosynthesis Z-scheme and S-scheme heterojunctions enabling efficient charge separation [1]. The core idea of the Z-scheme photocatalysts is to create a heterostructure from two semiconductors, of strong oxidative and strong reductive abilities, with proper alignment of the conduction and valence bands. In this work, we electrosynthesized BiVO₄ on FTO electrode and combined it with graphitic g-C₃N₄. The system was also modified with Au nanoparticles, deposited on BiVO₄ before application of g-C₃N₄. The electronic structure of the components was

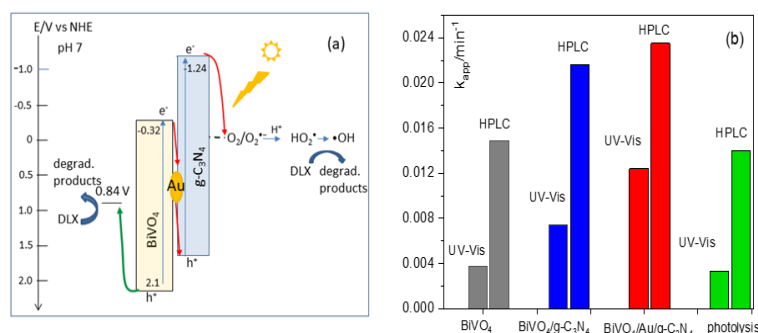

Fig.1. Proposed band diagram of BiVO₄/Au/g-C₃N₄ (a), and DLX degradation rate constants determined from UV-Vis spectra and HPLC measurements for different composites (b).

contained smaller amount of toxic products than that illuminated in the presence of BiVO₄/g-C₃N₄. These differences are discussed in terms of different pathways of charge separation in these two composites.

Acknowledgments: The authors are grateful for financial support from Polish National Science Centre (2019/33/B/ST5/01720).

[1] X. Li, C. Garlisi, Q. Guan, S. Anwer, K. Al-Ali, G. Palmisano, L. Zheng, *Materials Today*, 47 (2021) 75-107.

Novel mechanism of redox-mediator catalytic electrochemical processes. Implication for chemical power sources of very high energy densities

Mikhail A. Vorotyntsev

*Frumkin Institute of Physical Chemistry and Electrochemistry RAS, Moscow, Russia
Lomonosov Moscow State University, Moscow, Russia; Université de Bourgogne, Dijon, France ...
e-mail: mivo2010@yandex.com*

Specific energy density represents a principal parameter of electrochemical energy sources. A way to reach its extremely high values was proposed by Yu.V. Tolmachev [1] on the basis of **aqueous multi-electron oxidizers**, in particular via reduction of **bromates** or **chlorates** to their halides:



Owing to high solubilities of both LiBrO_3 and LiBr salts, and the 6-electron transfer per one reagent species, thermodynamic estimations result for the specific redox capacity of reaction (1) for $X = \text{Br}$ in 790 Ah/kg and 1400 Ah/dm³ of saturated LiBrO_3 solution (even greater at elevated temperatures). Its combination with the H_2 oxidation at anode gives for the specific energy density of the device: 740 Wh/kg and 865 Wh/dm³, i.e. much greater than that for modern Li-ion batteries.

The key problem is related to **the absence of a redox activity of BrO_3^-** within the needed potential interval, even at specially modified electrode. We proposed [2] to carry out global reaction (1) as a **redox-mediator process** which consists of two (electrochemical and chemical) steps:

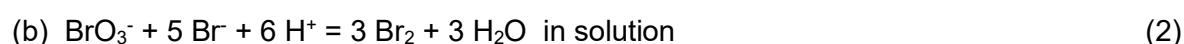
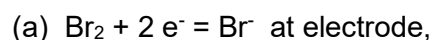

i.e. it is based on mutual cyclic transformations of the components of the Br_2/Br^- redox couple.

Scheme (2) resembles the well-known **catalytic redox-mediator mechanism (EC' or EC-cat)**:

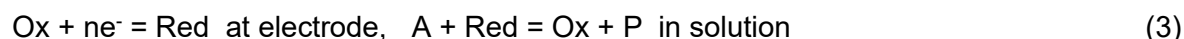

where A is a principal oxidant, P: reaction product (A and P: non-electroactive at electrode). If the bulk-solution concentration of A exceeds strongly that of catalytic species Ox: $A^0 \gg \text{Ox}^0$, then the **diffusion-limited current, j^{max}** , for the RDE (rotating disk electrode) configuration is **proportional to Ox^0** while for a fixed value of Ox^0 **large values of j^{max}** are reached **for an intensive agitation** of solution.

Quite unexpectedly, our theoretical analysis of the maximal RDE current, j^{max} , for scheme (2) gave **totally different results**. For **high rotation frequencies** the maximal current is close to the **diffusion-limited current due to electroreduction of species Br_2** (step 2a), i.e. **proportional to its bulk-solution concentration**, without any effect of chemical step 2b. For a **weaker solution agitation**, the current, j^{max} , **increases enormously upon diminution of the rotation frequency**, reaching very high values which **exceed the diffusion-limited current due to species BrO_3^-** (despite their non-electroactivity at

electrode), **even if the bulk-solution concentration of the catalytic component, Br₂, is very low.**

These **surprising theoretical predictions** for RDE (as well as for micro- and porous flow-through electrodes [3,4]) were later confirmed by direct experiments for the bromate system [5]. This analysis allowed us to design and to test **ever-first H₂-MBrO₃ discharge devices** [6] which showed the possibility to reach **very high current and power densities** (over 1.5 A/cm² and 1 W/cm²), with **almost complete** (93%) bromate-to-bromide transformation (1) in the bromate-acid solution, **without addition of any redox mediator**, upon **its single passage** through the device, contrary to predictions of the EC-cat mechanism for scheme (3).

This rapid transformation of bromate takes place even at cheap electrodes, e.g. at the surface of pores of a non-modified flow-through carbon paper or carbon felt. It is catalyzed by a very low concentration of Br₂ that is generated in the course of the bromate-acid solution preparation, being **sufficient for the reaction to proceed under the diffusion-limited regime for bromate ion.**

Thus, bromate electroreduction (2) represents an example of a **novel electrochemical mechanism (EC-autocat) possessing unique mass-transport and catalytic features.**

Thermodynamic predictions for reaction (1) at X = Cl are even more promising, e.g. 1580 Ah/kg and 3100 Ah/dm³ for the capacity at room temperature. We have revealed [7,8] that **the chlorate-to-chloride transformation** can also be performed **via the same EC-autocat mechanism**, even though its reaction scheme is **different** from (2). As a result, **ever-first H₂-MClO₃ batteries** have been home-made by our team [7].

Acknowledgments: With financial support of the Russian Science Foundation (grant 23-13-00428).

[1] Yu.V. Tolmachev, A. Pyatkivskiy, V.V. Ryzhov, D.V. Konev, M.A. Vorotyntsev, *J. Solid State Electrochem.*, **2015**, 19(9), 2711

[2] (a) M.A. Vorotyntsev, D.V. Konev, Yu.V. Tolmachev, *Electrochim. Acta*, **2015**, 173, 779; (b) M.A. Vorotyntsev, A.E. Antipov, *Electrochim. Acta*, **2017**, 246, 1217; (c) M.A. Vorotyntsev, D.V. Konev, *Electrochim. Acta*, **2021**, 391, 13891; (d) M.A. Vorotyntsev, P.A. Zader, *J. Electroanal. Chem.*, **2023**, 939, 117331

[3] M.A. Vorotyntsev, A.E. Antipov, *Electrochim. Acta*, **2017**, 258, 544

[4] M.A. Vorotyntsev, A.E. Antipov, *Electrochim. Acta*, **2019**, 323, 134799

[5] (a) A.D. Modestov, D.V. Konev, A.E. Antipov, M.M. Petrov, R.D. Pichugov, M.A. Vorotyntsev, *Electrochim. Acta*, **2018**, 259, 655; (b) D.V. Konev, A.E. Antipov, M.M. Petrov, M.A. Shamraeva, M.A. Vorotyntsev, *Electrochem. Comm.*, **2018**, 86, 76

[6] (a) A.D. Modestov, D.V. Konev, O.V. Tripachev, A.E. Antipov, Y.V. Tolmachev, M.A. Vorotyntsev, *Energy Technology*, **2018**, 6, 242; (b) A.D. Modestov, D.V. Konev, A.E. Antipov, M.A. Vorotyntsev, *J. Solid State Electrochem.*, **2019**, 23, 3075

[7] D.V. Konev, O.I. Istakova, E.A. Ruban, A.T. Glazkov, M.A. Vorotyntsev, *Molecules*, **2022**, .27, 5638

[8] M. A. Vorotyntsev, P. A. Zader, O. A. Goncharova, D. V. Konev, *Molecules*, **2025**, 30, 3432

Chapter 2: Invited oral presentations

Authors:

Fabiana Arduini
Jorge Correia
Samer Dawoud
Luigi Falciola
Marília Goulart
Magdalena Graczyk-Zajac
Andrew Hainer
Huangxian Ju
Svetlozar Ivanov
Olga Kasian
Marijana Kraljić Roković
Veronika Laurinavichyute
Mariangela Longhi
Marcin Opallo
Alain Pailleret
Bernardo Patella
Valentina Pifferi
Peter Rapta
Alessandro Silvestri
Terry Steele
Zbigniew Stojek
Monika Wilamowska-Zawlocka
Yao Yao
Aishui Yu
Chiara Zanardi
Kamila Zarebska
Lili Zhang

Printed Electrodes Modified With Cost-Effective Carbon Black Nanomaterial For Smart Electrochemical (Bio)Sensors

Fabiana Arduini

University of Rome Tor Vergata, Department of Chemical Science and Technologies, via della Ricerca Scientifica, 00133, Rome, Italy

e-mail: fabiana.arduini@uniroma2.it

Graphene is one of the leading materials in the current electrochemical sensor scenario, thanks to its unique properties. The presence of graphene on the surface of the working electrodes can improve the electroanalytical performances by enhancing the electron transfer at the surface of modified electrodes. In recent years, another interesting carbonaceous nanomaterial has become increasingly interesting, due to its excellent conductive and electrocatalytic properties: Carbon Black (CB). Herein, we present the results obtained over the last approximately fifteen years, with more than 40 publications on the use of CB for the development of various printed electrochemical sensors and biosensors, including paper-based and 3D-printed ones, demonstrating the versatility and effectiveness of this nanomaterial as a printed working electrode nanomodifier.

Acknowledgments: The authors acknowledge the financial support from the European Union's Horizon Europe research and innovation programme under the project RELIANCE (GA 101058570).

Coupled Electrochemical–Ellipsometric Investigation of Unique Redox-Induced Swelling in PEDOT:PSS Prepared at Low Temperature

Daniel R. Santos¹, Ana S. Viana¹, Upul K.G Wijayantha², Killian Lobato³, Jorge P. Correia¹

¹ Centro de Química Estrutural, Institute of Molecular Sciences, Faculdade de Ciências, Universidade de Lisboa, Portugal, ² Centre for Renewable and Low Carbon Energy, Cranfield University, Cranfield, UK, ³ Instituto Dom Luiz, Faculdade de Ciências, Universidade de Lisboa, Campo Grande, 1749-016 Lisboa, Portugal.

e-mail: jorge.correia@fc.ul.pt

Poly(3,4-ethylenedioxythiophene) (PEDOT) is an electronically conducting polymer (ECP) with physical and chemical properties [1] that make it highly suitable for energy storage applications. Due to the low solubility of its monomer in aqueous media, sodium poly(4-styrene sulphonate) (PSS) can be used during the polymerisation process to enable the formation of a stable monomer dispersion. This polyanion does not contribute actively to charge transport, as the anionic charges are immobilised within the polymeric matrix and balanced by cations originating from the electrolyte [2]. It has been demonstrated that the temperature and the synthesis mode strongly influence the pseudocationic character of the polymer, that is, the expulsion of cations during oxidation and their uptake during reduction [3]. This phenomenon, achieved to a large extent in PEDOT:PSS films prepared under galvanostatic conditions at low temperatures [4], is the desired process for application as a cathode material in sodium-ion batteries.

In this work, PEDOT films doped with PSS were galvanostatically synthesised at 0 °C on platinum electrodes from aqueous solutions containing the monomer and the polyanion, using different polymerisation charges (7.5–37.5 mC·cm⁻²). Their ellipsometric parameters (Ψ , Δ) are measured as a function of potential during redox conversion in an organic medium (NaClO₄ in acetonitrile solution). The Ψ - Δ representations of the films at selected potentials enabled simulation of the film-thickening effect on the dielectric constants as a function of the applied potential and, consequently, at different doping levels. The fitting procedure employ a three-phase homogeneous physical model (ambient:film:substrate), which enables an estimation of the refractive index, extinction coefficient, and film thickness (for a given growth charge) as a function of the applied potential – Figure 1. The obtained optical constants provided insights into the specific properties of the polymer imparted by low-temperature synthesis, as well as the distinctive swelling/shrinking behaviour associated with the pseudocationic character of the doping process – Figure 2.

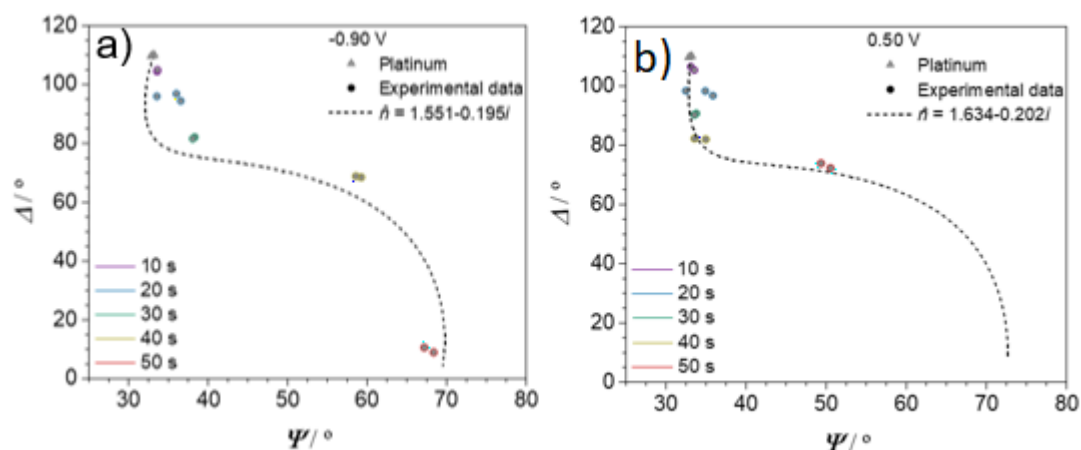

Fig. 1 - Computed Δ vs. Ψ (dashed) curve corresponding to the thickening of a film with a given complex refractive index indicated in each graph (assuming a three-phase model) and experimental data points (dots) collected in the anodic voltammetric scan at a) -0.90 V, b) 0.50 V.

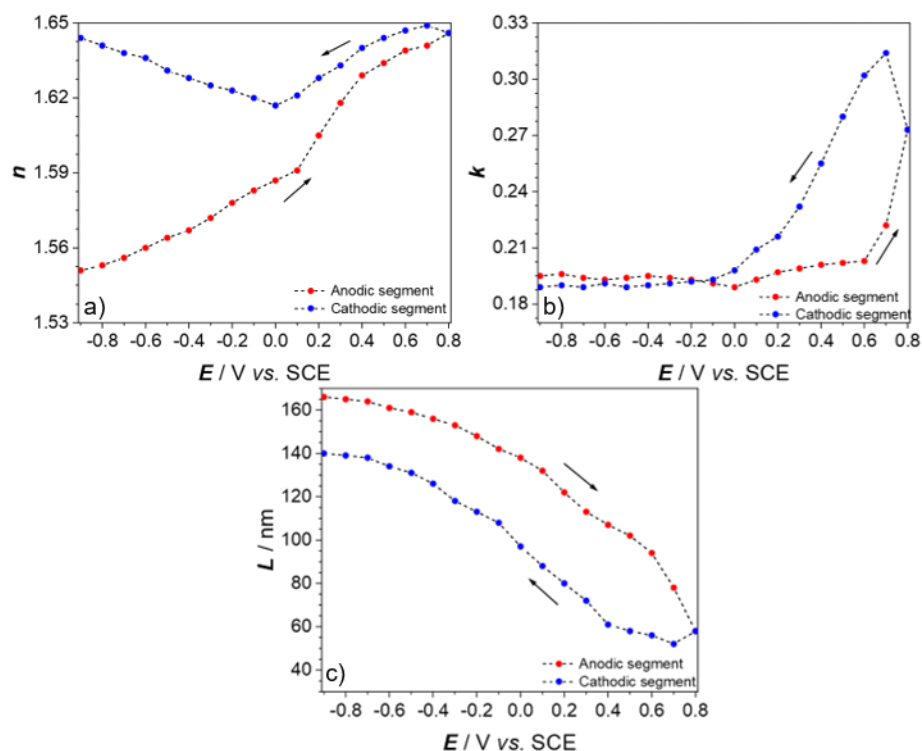

Fig. 2 - a) Refractive index, b) extinction coefficient, c) thickness variation throughout the redox conversion (in 0.1 M NaClO₄ in CH₃CN at $\nu = 50 \text{ mV}\cdot\text{s}^{-1}$ at room temperature) of PEDOT:PSS synthesised in galvanostatic mode at 0 °C during 50 s.

Additional support for the validity of the model used to calculate the relevant ellipsometric information, namely the unexpected increase of the k value at $\lambda = 633 \text{ nm}$ with the electrode potential, was provided by *in-situ* UV-Vis reflectance spectroscopy – Figure 3. Moreover, *in-situ* atomic force microscopy was used to assess the morphological changes that occurred during the oxidation and reduction of the film under an applied potential. The AFM also shows that the film shrinks during oxidation and swells upon reduction, reversibly, a behaviour that contrasts with what is typically reported in the literature for PEDOT films [5].

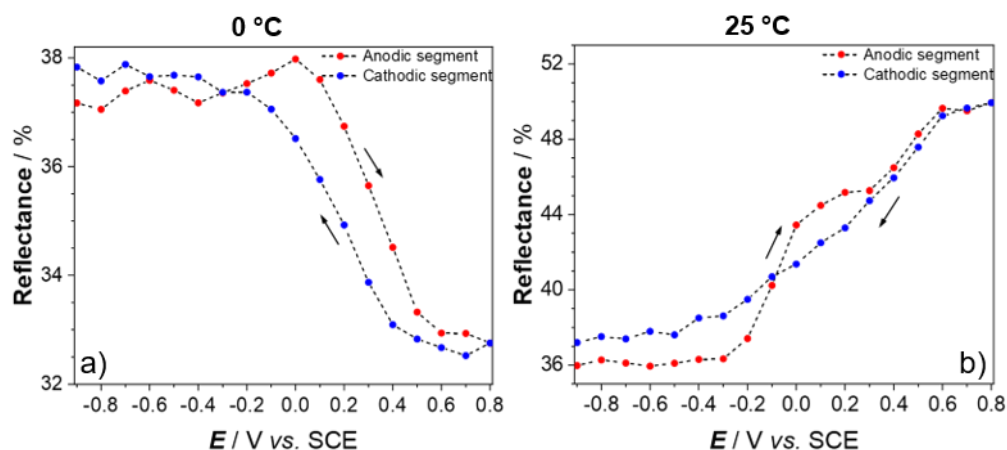

Fig. 3 - Reflectance values as a function of electrode potential ($\lambda = 632.8$ nm) for a film synthesised at a) 0 °C and b) 25 °C.

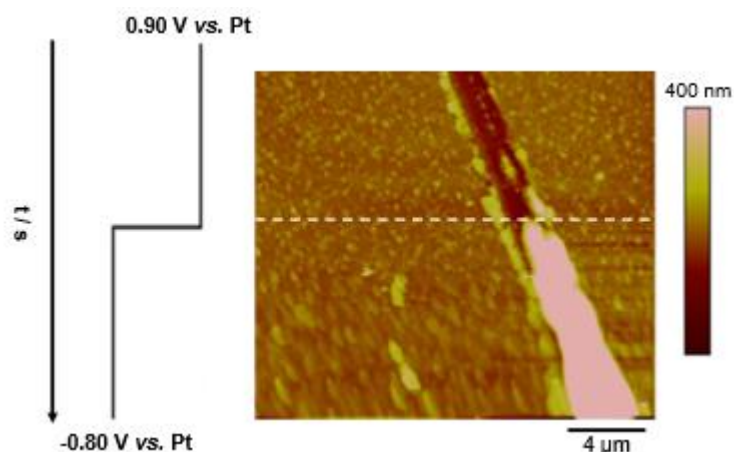

Fig. 4 - In-situ AFM image of a PEDOT:PSS film in 0.1 M NaClO₄ acetonitrile solution at room temperature, formed galvanostatically at $I_g = 0.75$ mA·cm⁻² during 35 s at 0 °C. Image recorded during a chronoamperometric experiment: top of the figure - oxidised state (0.90 V) and, bottom of the figure - reduced state (-0.80 V).

Acknowledgments: Centro de Química Estrutural is a Research Unit funded by FCT through projects UID/00100/2025 and UID/PRR/00100/2025. Institute of Molecular Sciences is an Associate Laboratory funded by FCT through project LAP/0056/2020. Instituto Dom Luiz is a Research Unit funded by Fundação para a Ciência e a Tecnologia I.P./MCTES through national funds (PIDDAC) – UID/50019/2025 and UID/PRR/50019/2025. Daniel R. Santos is also supported by the Fundação para a Ciência e a Tecnologia PhD grant SFRH/BD/148805/2019.

[1] Z. Zhang, H. Wang, H. Yoshikawa, D. Matsumura, S. Hatao, S. Ishikawa, W. Ueda. *ACS Appl. Mater. Interfaces*, **2020**, 12, 6056-6063.

[2] C. Dingler, R. Walter, B. Gompf, S. Ludwigs. *Macromol*, **2022**, 55, 1600-1608.

[3] D.R. Santos, J.F. Zeferino, A.S. Viana, K.G.U Wijayantha, K. Lobato, J.P. Correia. *Electrochim. Acta*, **2025**, 518, 145760.

[4] D.R. Santos, J.F. Zeferino, A.S. Viana, K.G.U Wijayantha, K. Lobato, J.P. Correia. *Electrochim. Acta*, **2025**, 529, 146343.

[5] A.I. Melato, A.S. Viana, L.M. Abrantes, *Journal of Solid State Electrochemistry*, **2010**, 14, 523-530.

PHOTOELECTROACTIVE COVALENT HYBRIDS BASED ON (ISO)PORPHYRIN-POLYOXOMETALATE ASSEMBLIES

S. Dawoud¹, B. Akhsassi¹, V. Badets¹, Y. Lin¹, J. Wang¹, and L. Ruhlmann¹

¹Université de Strasbourg, Laboratoire d'Electrochimie et de Chimie Physique du Corps Solide, Institut de Chimie de Strasbourg, UMR 7177, 4 rue Blaise Pascal, 67000, Strasbourg.

e-mail: samer.dawoud@etu.unistra.fr

Polyoxometalates (POMs), are promising candidates for various photoelectrochemical applications due to their excellent photosensitivity, redox, and catalytic properties, as well as their relative stability [1]. However, POM clusters in their ground state can primarily be excited by UV light, which induces a charge transfer from oxygen atoms to the d^0 transition metal. This limits the application of POMs in solar-driven catalysis [2]. In order to address this problem, we have designed covalently (iso)porphyrin–polyoxometalate hybrid materials [3], such as $\text{Fe}^{\text{III}}\text{POM-ZnT}_2\text{isoP}^*$ copolymer, by electropolymerization of the 5,15-ditolylporphyrin of Zn (ZnT_2P) in the presence of the hybrid POM namely Nu-MPOM-Nu ($\text{Nu} = \text{Py}, -\text{NH}_2, -\text{CH}_2\text{OH}, \text{etc.}; \text{M} = \text{Fe(III)}, \text{Mn(III)}, \text{Co(III/II)}, \text{Zn(II)}, \text{Cu(II)}, \text{Ni(II)}, \text{etc.}$) where the (iso)porphyrin subunit acts as an electron donor and the POM building block serves as an electron acceptor.

This process was monitored using cyclic voltammetry or chronoamperometry and EQCM (Electrochemical Quartz Crystal Microbalance). Their electrical properties were studied using electrochemical impedance spectroscopy (EIS) and their photovoltaic performances were evaluated through photocurrent transient measurements under visible–NIR light irradiation. The photocurrent for the $\text{MPOM-ZnT}_2\text{isoP}^*$ copolymer reached up to $-600 \mu\text{A cm}^{-2}$ with only a thickness of the film of 100 nm. In addition to their photocurrent activity, these copolymers were also tested for the photoelectrocatalytic reduction of nitrite ions and nitrous acid ($\text{NO}_2^-/\text{HNO}_2$) at various pH, confirming their efficiency toward visible-light-driven redox transformations. Finally, the morphology characterization was carried out using Atomic Force Microscope (AFM). However, the application of hybrid materials in the energy conversion domain still requires further investigation including DEMS (Differential Electrochemical Mass Spectrometry) measurements which are under work.

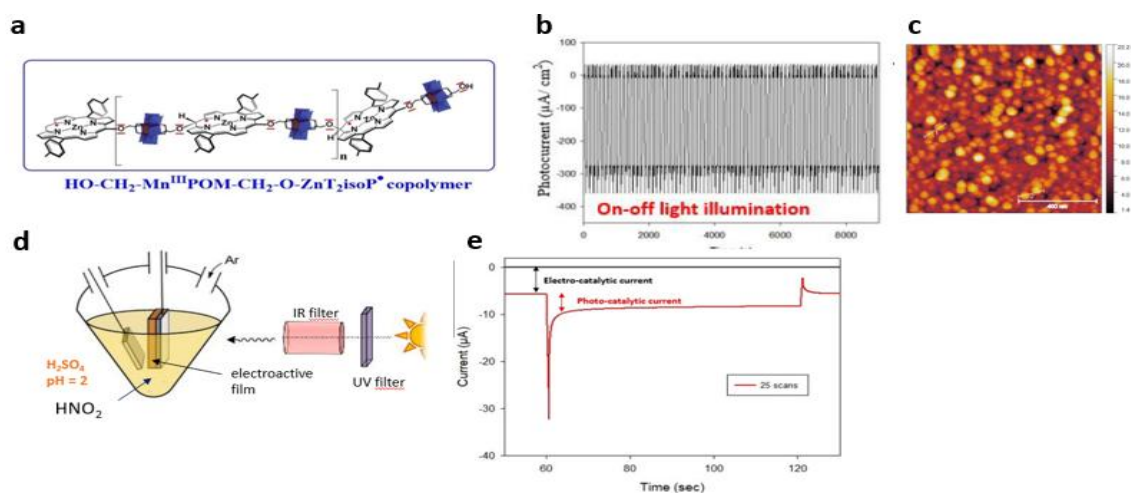

Figure 1. a) Electropolymerization process; b) Transient photocurrent test within 4 hours; c)

Morphology characterization by AFM; d) and e) Set-up and photo-electrocatalytic current of NO_2^- / HNO_2 reduction.

Acknowledgments: Foundation Jean-Marie Lehn as well as the ITI CSC (Chemistry of the Complex System) is warmly thanks for the support grant.

References:

- [1] S. Wang, G. Yang. *Chem. Rev.*, **2015**, 115, 4893- 4962.
- [2] C. Allain, S. Favette, L. Chamoreau, J. Vaissermann, L. Ruhlmann, B. Hasenknopf. *Eur. J. Inorg. Chem.*, **2008**, 2008, 3433- 3441.
- [3] Y. Liang, M. N. Sokolov, M. A. Mikhaylov, C. Boudon, V. Badets, A. Bonnefont, L. Ruhlmann, *Electrochimica Acta*, **2021**, 338, 138493.

Advanced hybrid or composite nanomaterials for next-generation (photo)-electroanalytical sensing

L. Falciola, V. Pifferi, W. Aidli, S. Comis, D. Fumagalli

Università degli Studi di Milano, Dipartimento di Chimica, Milano, Italy e-mail: luigi.falciola@unimi.it

In recent years, significant progress has been made in developing advanced sensors that leverage the properties of hybrid and composite materials. Rather than merely exploiting the individual photochemical or electrochemical characteristics of each component, modern sensing strategies increasingly focus on the **synergistic effects of heterojunctions**, which yield superior and often unexpected analytical features.

This technological framework enables the design of:

- (i) **photoactive electrodes** that enhance signal-to-noise ratios for high-sensitivity applications;
- (ii) **photo-renewable surfaces** for robust anti-fouling and anti-passivation properties;
- (iii) **dual-mode or ratiometric platforms** for rapid, accurate, and sensitive self-calibrating analytical determinations.

These advancements provide powerful new tools for environmental trace analysis.

In this context, this presentation highlights our research group's ongoing efforts to engineer **tailor-made materials** designed for targeted sensing applications. Alongside a comprehensive overview of the field, we will discuss (demonstrating how innovative material design translates into high-performance analytical devices) our most significant recent results:

- heterojunctions formed by TiO₂ and Au nanoparticles for the determination of ciprofloxacin [1];
- graphitic carbon nitride (g-C₃N₄) supported copper oxide nanoparticles (CuO), where the oxide nanoparticles are dispersed on the graphitic nanosheets, for the detection of nitrate ions at neutral pH [2];
- a well-organized system of graphene quantum dots, benzoquinone and cyclodextrins for the detection of electroactive (o-toluidine) and non-electroactive (cholesterol) molecules [3].

[1] D. Fumagalli, S. Comis, V. Pifferi, L. Falciola, *ChemElectroChem*, **2023**, e202201136.

[2] W. Aidli, D. Fumagalli, H. Helli, L. Falciola, V. Pifferi, *ChemElectroChem*, **2024**, e202300557.

[3] W. Aidli, V. Pifferi, ..., L. Falciola, *Electrochimica Acta*, **2023**, 464, 142936.

Balancing Life's Currents: Wiring Redox Therapy and Electrochemistry

Marília O. F. Goulart,¹ Ana C. F. Santos,¹ Danyelle C. Santos,¹ Fabrícia R. Ferreira,¹ Fabiane C. A. Galdino,¹ Anderson S. de Almeida,¹ André F. A. Xavier,¹ Laisa Bulhões,¹ Felipe C. Silva,¹ Ana L. A. Costa,¹ Bruno dos Santos,² Thaissa L. Silva,² Alane C. M. de Oliveira,³ Marilene T. Fragoso,¹ Jadriane A. Xavier,¹ Fabiana A. Moura,³ Antonio E. G. Santana,⁴ C. Amatore,⁵ Lauro T. Kubota.⁶

¹*Instituto de Química e Biotecnologia, Universidade Federal de Alagoas (UFAL), Maceió, AL, Brazil,* ²*Núcleo de Ciências Exatas – NCEX, UFAL – Campus de Arapiraca, Arapiraca, AL, Brazil,* ³*Faculdade de Nutrição, UFAL,* ⁴*CECA, UFAL,* ⁵*École Normale Supérieure, Département de Chimie, CNRS-ENS-SU-PSL, 75231 Paris, France,* ⁶*Instituto de Química, UNICAMP, Campinas, Brazil*
e-mail: mariliaofg@gmail.com

Redox therapy is a promising strategy in precision medicine for controlling oxidative stress and reestablishing cellular homeostasis across numerous therapeutic contexts, including cancer, neurodegeneration, and chronic inflammation. The core of this approach is the realization that antioxidants and reactive oxygen species (ROS) are not fixed components but active regulators, and that treatment efficacy depends on maintaining a redox equilibrium that varies with surrounding conditions [1].

Electrochemistry provides a strong foundation for the development of this field by enabling quantitative monitoring, controlled intervention in redox processes, and mechanistic understanding. Cyclic voltammetry and amperometry are electrochemical techniques that enable real-time profiling of redox-active biomolecules. This yields indicators of disease progression and therapy efficacy. These methods also ensure that redox-active drugs have optimized electron-transfer properties for selective action in diseased states by directing their rational design [2]. Further, electrochemistry underpins the development of redox-sensitive nanocarriers that deliver drugs in response to oxidative stress. Systemic toxicity is decreased, and specificity is improved. An approach to selectively kill cancer cells or revitalize damaged tissues is to electrochemically regulate ROS production [3].

A paradigm change from broad-spectrum antioxidant supplements to context-aware, mechanistically accurate therapies is represented by the integration of electrochemical monitoring, drug design, targeted delivery, and therapeutic modulation. Electrochemistry bridges the gap between basic redox biology and clinical application, making redox therapy a precision-guided field that can adapt treatments to each patient's unique redox state.

Our group has worked on several of these strategies, measuring some of the most relevant redox biomarkers (mainly thiol-based aminoacids, oxidative stress ones, and enzymatic cofactors) (Fig.1), using several electrode surfaces, chemically modified ones, including selective MIPS, magnetic or not, for glutathione and homocysteine, among others. Bioanalysis in diseased tissues or fluids (from animal models or cells) was employed to

investigate oxidative stress-based diseases. [4-6]. Electrochemical studies guided the design of compounds that selectively disrupt the metabolism of different cell types by exploiting their altered redox environment, as well as the design of nanocarriers for targeted drug delivery.

By mapping the redox switch, electrochemistry helps to determine when antioxidants are protective versus when they risk becoming pro-oxidants, a topic that will also be discussed, with examples [7,8], including electrochemically based antioxidant assays [9].

The limitations, pitfalls, and future directions of this integrated, multidisciplinary, and still controversial research area will be discussed.

Acknowledgements: CAPES, FAPEAL, CNPq, Inctbio-LK, for financial resources.

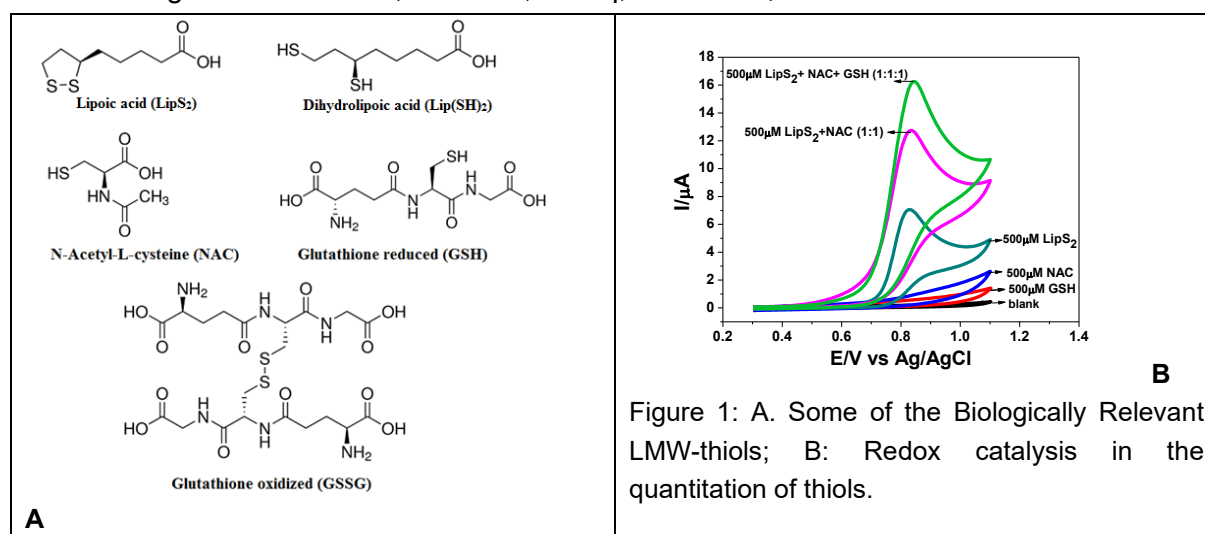

Figure 1: A. Some of the Biologically Relevant LMW-thiols; B: Redox catalysis in the quantitation of thiols.

References

- 1) <https://doi.org/10.1007/s10008-020-04542-0>
- 2) <http://dx.doi.org/10.1016/j.bios.2013.06.036>
- 3) <https://doi.org/10.1016/j.talanta.2024.126290>
- 4) <https://doi.org/10.1007/s10008-025-06255-8>
- 5) <https://doi.org/10.1039/b718116g>
- 6) <https://doi.org/10.1016/j.snb.2021.130171>
- 7) <http://dx.doi.org/10.1016/j.jelechem.2020.114919>
- 8) <http://dx.doi.org/10.1002/celc.201600504>
- 9) <https://doi.org/10.3390/antiox14091082>

Enhancing the Electrochemical Performance of Sn-based Anodes for Sodium-Ion Batteries: Impact of Processing and Operational Parameters

Alexander Kempf¹, Ralf Riedel¹, Philipp Adelhelm², Magdalena Graczyk-Zajac^{1,3}

¹*Institute of Materials Science, Darmstadt University of Technology, Otto-Berndt-Str. 3, 64287 Darmstadt, Germany*

²*Institute of Chemistry, Humboldt University of Berlin, Brook-Taylor-Str. 2, 12489 Berlin, Germany*

³*EnBW Energie Baden-Württemberg AG, Durlacher Allee 93, 76131 Karlsruhe, Germany*
e-mail: m.graczyk-zajac@enbw.com

Sodium-ion batteries (SIBs) have attracted increasing attention as promising alternatives for widely spread Li-ion storage [1]. Among potential anode materials, Sn-based systems offer high theoretical capacities due to their ability to store sodium via the formation of binary alloys. This work investigates various strategies to enable and improve the electrochemical performance of tin-based composites, while addressing key challenges such as the low melting point of Sn ($T_m = 231.9\text{ °C}$) during material processing and the pronounced volume expansion ($\sim 420\%$) occurring during battery operation.

Herein, Sn metallic particles are synthesized in-situ via carbothermal reduction of SnO_2 to obtain a homogenous distribution within a fructose-derived carbon matrix. To overcome limited Sn confinement and suppress agglomeration, a two-step thermal process combining carbonization and ultra-fast reduction is employed, enabling high Sn loadings with controlled morphology. The resulting C/Sn composites deliver an initial sodiation capacity of 749 mAh g^{-1} with an initial coulombic efficiency of 83.2%, retain 351 mAh g^{-1} at 37 mA g^{-1} , and exhibit excellent rate capability with 344 mAh g^{-1} at 2380 mA g^{-1} . Cycling protocol optimization reveals that a combined low-current activation followed by high-current cycling significantly enhances stability, achieving 71.6% capacity retention (536 mAh g^{-1}) after 100 cycles and a mean coulombic efficiency of 99.8%. Voltage profile evolution indicates a current-dependent shift in the electrochemical mechanism, contributing to improved performance [2,3].

Acknowledgments: The authors gratefully acknowledge the financial support by the German Research Foundation (DFG) in the frame of the BEETHOVEN Classic 3 – Polish-German Funding Initiative (GR 4440/4-1) and the EU project SIMBA (sodium-ion and sodium metal batteries for efficient and sustainable next-generation energy storage) under grant agreement number 963542.

[1] K. Kumar, R. Kundu, *ACS Appl. Energy Mater.* **2024**, *7*, 3523.

[2] A. Kempf, M. Graczyk-Zajac, R. Riedel, *ACS Materials Lett.* **2025**, *7*, 275.

[3] A. Kempf, P. Adelhelm, M. Graczyk-Zajac, *Batter. Supercaps*, **2025** doi:10.1002/batt.202500340.

Improving the sensitivity and versatility of differential electrochemical mass spectrometry for the mechanistic analysis of electrode degradation in water electrolysis

A. Hainer¹, L. Lahn^{1,2}, and O. Kasian^{1,2}

¹*Helmholtz-Zentrum Berlin GmbH, Helmholtz Institute Erlangen-Nürnberg, Erlangen, Germany*

²*Friedrich-Alexander-Universität Erlangen-Nürnberg, Erlangen, Germany*

e-mail: andrew.hainer@helmholtz-berlin.de

Wider spread adoption of water electrolyzers is greatly limited by the overall instability of the electrocatalyst materials. Understanding the fundamental mechanisms of degradation reactions is of vital importance for the future design of improved catalyst systems. Differential electrochemical mass spectrometry (DEMS) is a useful tool for time-resolved analysis of volatile and gaseous species formed during electrochemical reactions [1, 2]. Applying DEMS-based methods to the study of degradation mechanisms requires enhanced sensitivity, as the relevant intermediates and products are formed trace amounts and have short lifetimes.

Here we present improvements to DEMS allowing for greater sensitivity and versatility for measuring volatile degradation products of Ruthenium and Iridium containing electrodes. Particular emphasis is placed on the design of electrochemical cells and electrode configurations, which are optimized to minimize mass-transport limitations and signal losses while maintaining well-defined electrochemical control. These improvements allow for the analysis of products previously difficult to study through such methods, thus improving the overall scope of systems that can be studied with DEMS.

[1] O. Kasian et. al., *Energy Environ. Sci.*, **2019**, 12, 3548-3555.

[2] K. Zhao et. Al., *Chem. Soc. Rev.*, **2024**, 53, 6917-6959.

Nanoemitters for Electrochemiluminescence: Mechanisms and Biosensing Applications

Huangxian Ju

State Key Laboratory of Analytical Chemistry for Life Science, School of Chemistry and Chemical Engineering, Nanjing University, Nanjing 210023, China

e-mail: hxju@nju.edu.cn

Electrochemiluminescence (ECL) biosensing is a powerful analytical technology due to its electrochemically controllable characters, low background interference, and high sensitivity. This report introduces the innovative ideas and research progress of our group in designing new ECL nanoemitters, probing novel ECL mechanisms and extending ECL biosensing applications.

In 2004, we presented a method to study the intrinsic ECL emission of quantum dots (QDs) in aqueous solution, and thus proposed the first ECL biosensor based on the emission, which brought a new field in ECL biosensing application of QDs and set off a research hotspot of ECL biosensing with inorganic nanoparticles. New mechanisms, including intermediate annihilation, the first ECL energy transfer mechanism, surface unpassivation, self-produced coreactant, coreactant consumption, electron and energy transfer, and target-induced structure switching ECL emission for biosensing and signal amplification were proposed. Besides QDs, a number of inorganic nanoparticles such as g-C₃N₄ nanosheets, AuNPs-enhanced g-C₃N₄, cobalt-based MOFs, electroactive MOFs, luminol or Ru(bpy)₃²⁺ loaded nanocomposites, dual-stabilizer-capped Au nanoclusters, and copper doped terbium MOFs were used as the emitters for design of new ECL biosensing mechanisms and development of ECL detection methods. In recent years, silole-, cyanovinylene- or Ru(bpy)₃²⁺ containing polymer dots (Pdots), AIE-active D-A type Pdots, dual RET-enhanced triple-component Pdots and coreactant-embedded Pdots, black phosphorus QDs and thermally activated delayed fluorescence polymer dots were designed to enhance the ECL emission for sensitive biosensing and bioimaging analysis of biomolecules, cell surface proteins and multiplex microRNAs. Some new ECL mechanisms such as the transformation of triplet excitons into singlets via reverse intersystem crossing (RISC), hybridized local and charge-transfer (HLCT) excitation, aggregation-induced delayed fluorescence (AIDF), aggregation-induced RET, intramolecular resonance energy transfer and electron transfer, and single-atom-induced hole concentration enhancement were thus proposed recently....

Acknowledgments: These works were supported by the National Natural Science Foundation of China.

Determination of phosphorus content from the electrogravimetric response of Ni-P layers during galvanostatic anodic polarization

M. Witt¹, I. Genov¹, A. Bund¹, S. Ivanov^{1,2}

¹ *Electrochemistry and Electroplating Group, Technische Universität Ilmenau, Ilmenau, Germany,*

² *Institute of Physical Chemistry, Bulgarian Academy of Sciences, Sofia, Bulgaria*

e-mail: svetlozar-dimitrov.ivanov@tu-ilmenau.de

Ni-P layers demonstrate various favorable functional characteristics, where the P content is the most important property-controlling factor. Therefore, the development of prompt and cost-effective methods for determination of the P quantity in the layer is important. In response to this challenge the current work proposes a simple and low-cost microgravimetric approach for rapid in-situ evaluation of the P content in galvanostatically deposited Ni-P layers. The method is based on the application of electrochemical quartz crystal microbalance (EQCM) for electrogravimetric analysis of Ni-P layers in acidic electrolyte environment. It was observed that Ni-P electrodeposition involves significant contribution of hydrogen evolution reaction, which strongly complicates the electrogravimetric determination of the P content. To circumvent this issue, anodic dissolution of Ni-P in acidic media was explored for galvanostatically deposited Ni-P layers. The method is based on evaluation of the apparent molar mass of the deposit, under the conditions of complete and homogeneous (non-preferential) Ni-P electrochemical dissolution [1]. Important factors, including deposition potential, current density and temperature are considered for understanding of the reaction mechanism corresponding to Ni-P redox behavior and its gravimetric response [1]. The approach can be realized in a sequential galvanostatic mode, enabling straightforward analysis of the current density impact on the layer composition. The analytical results obtained by means of EQCM are verified by EDX and XPS spectroscopy methods.

[1] M. Witt, I. Genov, A. Bund, S. Ivanov, *J. Electroanal. Chem.*, 2026, 1002, 119725.

Acknowledgment: The authors would like to thank Dr. A. Knauer and A. Hartung from the Center of Micro- and Nanotechnologies (ZMN) (DFG RI sources reference: RI_00009), a DFG-funded core facility (Grant No. MU 3171/2-1+6-1, SCHA 632/19-1+27-1, HO 2284/4-1+12-1) at TU Ilmenau, for the measurement of the XPS spectra and Dr. A. Ispas for the technical assistance in the arrangement of the EQCM setup.

Design of Durable Thin-Film Electrocatalysts with Reduced PGM Content

O. Kasian^{1,2}, L. Lahn^{1,2}, A. Hainer¹, E. Celik¹

¹*Helmholtz-Zentrum Berlin GmbH, Helmholtz-Institute Erlangen-Nürnberg, Erlangen, Germany*

²*Department of Materials Science and Engineering, FAU Erlangen-Nürnberg, Erlangen, Germany*

e-mail: olga.kasian@helmholtz-berlin.de

Electrocatalytic processes play a pivotal role in the transition of energy sector towards renewables, as many sustainable energy-storage technologies rely on efficient and reversible conversion between chemical and electrical energy. However, the practical implementation of electrochemical energy conversion and storage devices is limited by low activity and insufficient durability of catalyst materials [1]. These challenges are especially pronounced in acidic fuel cells and electrolyzers, where corrosion-resistant noble metals such as platinum and iridium continue to be indispensable. Despite their excellent performance, the scarcity and high cost of these materials represent a major barrier to large-scale deployment of electrochemical technologies. Addressing this issue requires strategies that significantly lower noble-metal content while maintaining both efficiency and durability. Achieving this goal requires a detailed atomic-level understanding of catalytic active sites, their reactivity, and the mechanisms that govern degradation under operating conditions [2-4].

In this presentation, we will discuss the design concepts aimed at minimizing Pt and Ir loadings in electrocatalysts without compromising functional performance. Special focus will be placed on polarization-induced changes in the composition and structure of surface and near-surface atomic layers of model thin-film catalysts in acidic electrolytes. Using a combination of advanced electrochemical measurements and state-of-the-art characterization techniques, including atom probe tomography, X-ray photoelectron spectroscopy and X-ray absorption spectroscopy, we explore stability of catalytically active surfaces. These insights enable the development of stabilization strategies that preserve activity at reduced noble-metal content. Overall, this work advances the understanding of structure–function relationships in electrocatalysis and provides guiding principles for the design of durable, high-performance catalysts with lower reliance on precious metals.

[1] Stamenkovic et. al. *Nature materials* 2017, 16 (1), 57-69

[2] Lahn et. al. *ChemElectroChem* 2024, 11(4), e202300399

[3] van der Merwe, *ACS Catalysis* 2023, 13 (23), 15427-15438

[4] Ruiz Esquiús et. al. *Journal of the American Chemical Society* 2023, 145 (11), 6398-6409

WO₃ modified by transition metals for photocatalytic application

M. Labudović, T. Lažeta, S. Kumar Pandey, S. Romac, H. Kušić, M. Kraljić Roković

University of Zagreb Faculty of chemical engineering and technology, Marulićev trg 19, Zagreb, Croatia

e-mail: mkralj@fkit.unizg.hr

Photoelectrochemical processes (PEC) have attracted increasing attention as green chemical processes that can effectively contribute to the degradation of target pollutants, hydrogen generation, or the synthesis of organic molecules. Various semiconductor materials, such as UV-responsive TiO₂ and ZnO₂, or visible light-responsive SnS₂, BiVO₄, Fe₂O₃, and WO₃, have been used for this purpose. WO₃ is an n-type semiconductor characterised by a band gap of 2.5–2.8 eV, excellent electron mobility, an appropriate hole diffusion length, and good stability in acidic media [1]. However, poor visible light response and rapid recombination of charge carriers limit the practical application of WO₃ as an effective photocatalyst. Structural modifications with transition metals can be used to adjust the band gap and enhance the photocatalytic efficiency of WO₃.

The aim of this study was to synthesize WO₃ layers by cathodic electrodeposition using a peroxotungstic acid precursor at fluorine-doped tin oxide (FTO) glass. In addition to WO₃, modified layers were prepared in a similar way by adding Zn, Ga, Mn, or Co salts to the peroxotungstic acid precursor. Modification was also carried out using spent active battery materials.

The properties of materials were characterized by linear sweep voltammetry electrochemical impedance spectroscopy, chronoamperometry, open circuit potential monitoring, UV/Vis spectroscopy, X ray diffraction, and scanning electron microscopy with energy dispersive X ray spectroscopy. Based on the obtained properties, the materials were applied for photoelectrochemical hydrogen generation and amoxicillin degradation.

Acknowledgments: The authors acknowledge the support through project HORIZON-MSCA-2024-SE-01 (WAVEE, Number: 101236518) and project Tailored solar-active materials for photocatalytic degradation of contaminants of emerging concern (SOL-MAT-CLEAN) (IP-2025- 02-8507)

[1]: Bu, L. Tan, S. Zhang, K. Xu, C. Zeng, *Catalysts*, **2025**, 1061.
<https://doi.org/10.3390/catal15111061>

Electrodeposition of Mixed $\text{Mo}_x\text{W}_{1-x}\text{O}_3 \cdot 2\text{H}_2\text{O}$ Films: From Solution Speciation to Electrochromic Kinetics and Ionic Transport

V. K. Laurinavichyute¹, E. E. Levin¹, A. A. Mironkova¹, A. A. Eliseev¹, Haoqin Xu², L. V. Pugolovkin¹

¹ *M.V. Lomonosov Moscow State University, Moscow, Russian Federation*

² *Northeast normal university, China*

e-mail: karmaranka@gmail.com

Hydrated tungsten oxide films are widely used as electrochromic materials, while partial substitution with molybdenum provides an efficient way to modify their redox and optical properties. In this work, hydrated mixed oxide films $\text{Mo}_x\text{W}_{1-x}\text{O}_3 \cdot 2\text{H}_2\text{O}$ were electrodeposited from acidic metastable tungstate–molybdate solutions over a broad range of Mo:W ratios, and the relationships between solution chemistry, film formation, and electrochromic response were analyzed.

The composition of deposition solutions was resolved using UV–Vis and Raman spectroscopy. Two mixed molybdotungstate polyanions, $[\text{H}_2\text{MoW}_{11}\text{O}_{40}]^{6-}$ and $[\text{H}_3\text{Mo}_3\text{W}_{15}\text{O}_{60}]^{9-}$, were identified as dominant precursors depending on molybdenum content. The prevalence of $[\text{H}_3\text{Mo}_3\text{W}_{15}\text{O}_{60}]^{9-}$ at intermediate and high Mo concentrations leads to a pronounced increase in deposition rate, exceeding that of pure tungstate systems by more than a factor of five.

Structural characterization by XRD, Raman spectroscopy, and SEM demonstrates that the deposited films form single-phase hydrated solid solutions $\text{Mo}_x\text{W}_{1-x}\text{O}_3 \cdot 2\text{H}_2\text{O}$ with molybdenum contents up to $x \approx 0.22$. Electrochemical and in situ optical measurements show that molybdenum incorporation shifts the onset of coloration to more positive potentials and enhances optical absorption in the visible range ($\approx 500\text{--}600$ nm). While coloration times increase moderately with Mo content, a strong suppression of self-bleaching is observed, indicating stabilization of the colored state. Effective diffusion coefficients were estimated for films with different molybdenum contents to qualitatively describe ionic transport in the hydrated mixed oxides. The variation of the diffusion coefficients correlates with changes in the film coloration rates and is discussed in the context of the observed electrochromic kinetics. Overall, the results demonstrate that controlled molybdenum incorporation allows tuning both deposition efficiency and electrochromic performance of hydrated mixed oxotungstate films, making them promising materials for electrochromic applications.

Acknowledgments: The authors acknowledge support from Lomonosov Moscow State University (State Assignment № AAAA-A21-121011590088-4).

Effect of Synthesis Parameters on the Morphological and Functional Properties of Nitrogen-Doped Carbon Nanocubes

Giulia Tonsi¹, Francesco Orsini², Mariangela Longhi¹

¹Università degli Studi di Milano, Dipartimento di Chimica, Via Golgi 19, 20133 Milano, Italy

² Università degli Studi di Milano, Dipartimento di Fisica, Via Celoria 16, 20133 Milano, Italy

e-mail: Mariangela.longhi@unimi.it

Nitrogen-doped carbon nanocubes represent a novel class of nanomaterials that has recently attracted significant interest due to their potential applications in fuel cells, electroanalysis, and medical diagnostics. However, their properties are still scarcely investigated.

In this study the influence of synthesis parameters on the morphological features and on the thermal, electrochemical, and active surface area properties of nitrogen-doped carbon nanocubes has been studied.

These nanomaterials are synthesized by chemical vapor deposition (CVD) at 800 °C using triethylenetetramine (TETA) as carbon and nitrogen precursor, ferrocene as catalyst, and magnesium oxide as substrate. The investigated synthesis parameters include: (i) catalyst concentration in the catalyst/precursor solution, (ii) dripping time, (iii) dripping flow rate, and (iv) catalyst nature.

Morphological analysis performed by TEM and HRTEM reveals that the nanocube dimensions, which consistently exhibit edge lengths of approximately 50 nm, are not affected by synthesis parameters. This behavior could be due to the MgO size acting as a hard template. Conversely, the number of graphene layers forming the nanocube walls, and therefore their thickness, is strongly influenced by the synthesis conditions. A linear relationship between wall thickness and both dripping time and flow rate is observed, as well as a correlation with catalyst concentration. The replacement of iron with cobalt as catalyst does not produce significant morphological differences.

AFM measurements, conducted in air and in aqueous solution, evidence a swelling phenomenon in water, more pronounced for nanocubes with thinner walls. BET analysis shows varying active surface areas with similar pore size distributions, without a clear correlation with wall thickness. DSC measurements reveal an endothermic peak for some samples, attributed to desorption of gases from the nanocube surface and cavities. Electrochemical characterization by cyclic voltammetry suggests the presence of confined diffusion phenomena.

Electrocatalysis(?) of O₂ reduction at non-metallated hypercrosslinked polymer modified electrodes

Shumaila Razzaque¹, Katarzyna Wielondek¹, Alla Dyachenko¹, Kostyantyn Nikiforov¹, Adam Kubas¹, Michal Bielejewski², Bien Tan³, Marcin Opallo¹

¹*Institute of Physical Chemistry, Polish Academy of Sciences, Warszawa, Poland,
e-mail: mopallo@ichf.edu.pl*

²*Institute of Molecular Physics, Polish Academy of Sciences, Poznan 60-179, Poland*

³*Huazhong University of Science and Technology, Wuhan, China*

⁴*University of Bath, Bath, UK*

One of the directions of ORR catalysts development is to eliminate the metallic components. Application of polymer catalyst is one of the possible solution and since 2005 [1] electrocatalytic properties of conducting polymers towards ORR were studied. However, in last few years researchers turned their attention to porous organic polymers (POPs) [2]. due to their large specific surface area, tunable pore size, tailorable frameworks, and high chemical stability in aqueous electrolytes. Importantly, POPs' ability for gas storage and/or separation [3] is a clear advantage for ORR, because of the limited solubility of oxygen in water. Although ORR electrocatalysis at non-metallated POPs was reported [4], the mechanism of reaction remains unclear. In our study we have focused on hypercrosslinked polymers (HCPs), because of the relatively simple synthesis from commercially available monomers, which can be easily scaled up.

Recently, ORR electrocatalytic activity of non-metallated and non-pyrolised HCPs was demonstrated [5]. Here we will present extension of that study. HCP's 3D hydrophobic rigid networks are formed by extensive crosslinking of organic monomers and are capable of trapping of gases [6]. Typically they consist aromatic units with heteroatoms, which are considered to be catalytic sites. Here we have synthesized HCPs particles from triphenylbenzene to secure 3D network and triphenylamine (TPA) to provide N-heteroatoms as prospective catalytic sites.



Importantly the distribution of the pores depends on the catalyst used in TPBA synthesis. Micropores are present in Al-TPBA, whereas in Fe TPBA macropores dominate. Their surface area is also different: 1137 vs. 438 m² g⁻¹.

In order to study electrocatalytic effect HCPs particles were immobilized in Nafion (HCP@Nafion) film deposited on “non-catalytic” glassy carbon (GC) electrode. Voltammetry in acidic solution show electroactivity of both TPBA related to ORR and redox process of TPA unit. ORR onset potential shift from few tens to over one hundred millivolts (depending on the method of synthesis and pH) is seen, what may indicate electrocatalytic effect. Next, chronoamperometric experiments were performed in conditions, when the rate of the electrode reaction is entirely

controlled by reactant transport, namely at “catalytic” Pt electrode [7]. The results indicate larger O₂ flux in HCP@Nafion film next to the electrode surface as compared to the bulk electrolyte. Moreover, this effect is more pronounced for HCP@Nafion electrode as compared to bare or Nafion modified electrode. Although O₂ diffusion coefficient in HCP film is significantly lower, its concentration (44 vs. 8 mM) is significantly higher than in electrolyte solution as it was earlier seen for intrinsically

microporous polymer film [7]. Therefore, at least part of onset potential shift may not be related to intrinsic catalytic effect. It seems to that TPBA particles form oxygen diffusion paths through the pores of hydrophobic and insulating polymer Considering that TPBA is an insulator, it seems to that electrocatalytic reaction occur at GC|HCP particle|electrolyte three phase junction. Analysis of results obtained at rotating ring disc electrode indicate proved that it follows mainly 2 electrons ORR pathway and H₂O₂ is the main product. Overall, we have demonstrated the potential of

non-metalated and non-pyrolized HCPs synthesized by solvent knitting for ORR electrocatalysis both in basic and acidic conditions. Here oxygen preconcentration overweighs its slow diffusion through HCPs particles network. This aspect of ORR reaction was not earlier studied for particulate porous polymer film embedded in ionomer. The important role of preconcentration of oxygen n ORR may be general for other porous polymers and this aspect requires further studies. The recently advocated concept of “triphasic gas storage” seems to fit to studied system [8].

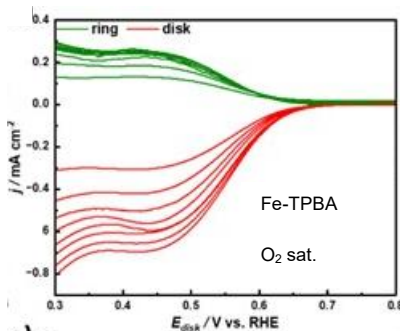
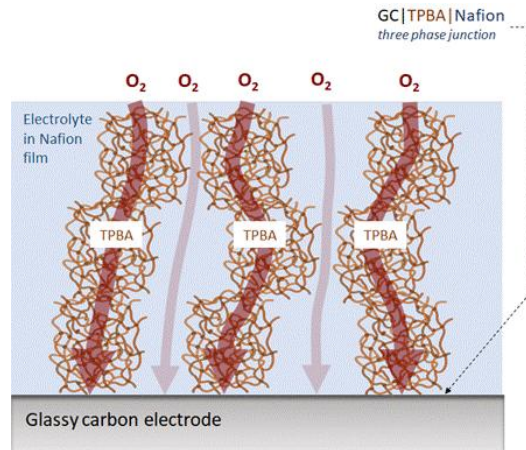
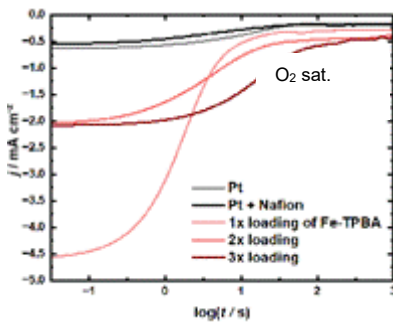
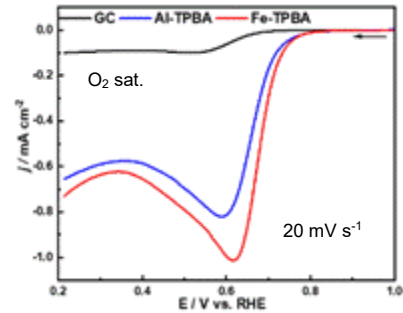
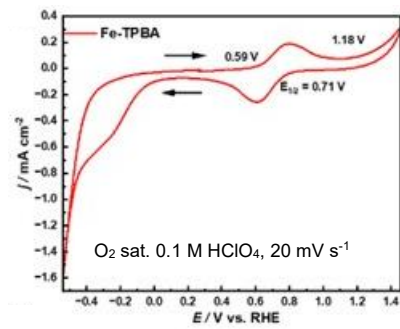

- [1] V.G. Khomenko, V.Z. Barsukov, A.Z. Katashinskii, *Electrochim. Acta*, **2005**, 50, 1675–1683.
- [2] D.H. Yang, Y. Tao, X.S. Ding, B.H. Han, *Chem. Soc. Rev.*, **2022**, 51, 761–791.
- [3] W. Liu, Y. Yang, L. Guo, J. Di, C. H. Lau, M. V. Bermeshev, L. Shao, *Chem. Eng. J.* **2024**, 498, 155569.
- [4] X. Yang, T. Chen, D. Liu, Z. Xiang, *Acc. Chem. Res.*, **2024**, 51, 761–791.
- [5] S. Razzaque, A. Dyachenko, A. Waqar, K. Dusilo, M. Opallo, *Electrochem. Commun.* **2024**, 167, 107800.
- [6] L. Tan, B. Tan, *Chem. Soc. Rev.*, **2017**, 46, 3322-3356.
- [7] M. Azevedo-Beluomin, M. Ramos-Stradiotto, M.V. Boldrin-Zanoni, M. Carta, N.B. McKeown, P.J. Fletcher, S. Sain, Z. Li, F. Marken, *ACS Appl. Mater. Interface*, **2024**, 16, 37865-37873.
- [8] Z. Li, C. T. Scott, T. Suzuki-Osborne, J. P. Lowe, D. Taylor, M. Carta, N. B. McKeown, A. D. Burrows, L. H. Mascaro and F. Marken, *Adv. Sci.* **2025**, e14182..

Amorphous Carbon Nitride thin films : from the tuning of their surface properties using the deposition parameters to their application in electroanalysis and energy conversion

A. Pailleret¹

¹*Sorbonne Université, CNRS, Laboratoire Interfaces et Systèmes Electrochimiques (LISE, UMR 8235), 75252 Paris, France*
e-mail: alain.pailleret@sorbonne-universite.fr

Amorphous Carbon Nitride (a-CN_x) thin films can easily be deposited on various substrates using the magnetron reactive cathodic sputtering technique, a well-known PVD-type vacuum deposition method. This latter requires then the use of a graphite target and an Ar/N₂ atmosphere as well as the adjustment of numerous deposition parameters among which one can cite power, totale pressure and nitrogen partial pressure. These latter are all known to allow the tuning of the atomic carbon/nitrogen ratio and the distribution of the numerous existing hybridization modes between carbon and nitrogen in the bulk of the resulting films as well as that of their (opto)-electronic properties and their surface chemical reactivity. It has been shown indeed that a-CN_x thin films behaving either as excellent electronic conductors or as p- or n- type semiconductors can be produced as a function of the chosen deposition parameters. These latter can also be used to tune the surface electronic conductivity of these films as well as the surface concentration of amine groups that can be used advantageously for their surface functionalization thanks to the covalent grafting of either chemical or biochemical entities on the surface of a-CN_x thin films. As a consequence of these numerous tunable properties, a-CN_x thin films are obviously highly attractive materials for application in electrochemistry, and more precisely in electroanalysis and energy conversion. This will be illustrated here through the use of a-CN_x thin films for the development of enzymatic biofuel cell cathodes operating by direct electron transfer between a grafted enzyme and a current collector [1], the electrochemical detection of mi-RiboNucleic Acids (mi-RNA) for medical diagnosis [2], the elaboration of semi-conductor junctions [3], and their recent integration in perovskite solar cells (PSCs).

Acknowledgments

The author wants to thank warmly the following Ph.D. students (A. Blout, M.C. Horny, J.C. Byers, Y. Dandal) and contributors (Pr. C. Jolivald (Sorbonne University, Paris, France), Dr O.A. Semenikhin (UWO, London (Ontario, Canada)), and Dr J. Gamby (CNRS, Saclay, France)) for their significant contribution to this research.

Bibliography

- [1] A. Blout, F. Billon, C. Calers, C. Méthivier, A. Pailleret, H. Perrot, C. Jolivald, *Electrochim. Acta*, 2018, 277, 255-267.
- [2] M.-C. Horny, F. Billon, A. Pailleret, C. Deslouis, ..., J.M. Siaugue, J. Gamby, *J. Electroanal. Chem.*, 2021, 895, 115395.
- [3] J.C. Byers, C. Deslouis, A. Pailleret, O.A. Semenikhin, *Russian J. of Electrochem.*, 2020, 56, 859-867

Nanostructured Electrochemical Sensors for Healthcare Applications

B. Patella¹, N. Moukri¹, F. Massaro¹, G. Aiello¹, S. A. Orlando¹, R. Inguanta¹

¹ *Department of Engineering, University of Palermo, Palermo, Italy*

e-mail: bernardo.patella@unipa.it

The rapid expansion of personalized medicine and point-of-care diagnostics demands analytical platforms capable of continuous, selective, and minimally invasive biomarker detection. *Electrochemical sensors* combined with nanostructured materials offer unique advantages such as high sensitivity, high surface area, miniaturization, low-cost and ease of operation. Here, we present four complementary strategies that demonstrate the feasibility and applicability of electrochemical sensors to support the transition of healthcare from hospital-centered models toward decentralized and patient-oriented medicine. We have developed *Paper-based microfluidic* devices demonstrating the potential of low-cost architectures for sweat analysis. Such platforms enable simultaneous detection of Cl⁻ ions and uric acid by combining tailored electrochemical interfaces with chromatographic paper, leading to rapid and selective measurements relevant to cystic fibrosis diagnostics, hydration monitoring, and metabolic assessment. Sustainable fabrication approaches, including Ag-based electrodes obtained from compact discs, have further expanded the scope of Cl⁻ detection, highlighting the role of circular materials in electrochemical device engineering.

For the monitoring of *neurodegenerative diseases*, we have synthesized an electrode made of rGO combined with Au NPs that enabled selective dopamine sensing with negligible interference from ascorbic and uric acids in urine. The electrocatalytic synergy between graphene and metallic NPs enhances kinetic and adsorption processes, providing high analytical performance for neurochemical monitoring.

Another application concern the development of Au nanowire-based sensors to quantify H₂O₂ released by human airway epithelial cells, offering real-time assessment of *oxidative stress* and supporting mechanistic studies on airway inflammation. This sensing approach has also been integrated into a multi-analyte platform capable of simultaneously measuring pH, uric acid and H₂O₂ content.

The last example concern the use of nanostructured gold-foam, coupled with an anti-fouling layer, enabling the use of electrochemical sensors for the *detection of proteins* in the fg/mL range, demonstrating the feasibility of highly sensitive biosensing in complex matrices such as saliva and cell culture medium.

Together, these solutions illustrate how nanostructured electrochemical sensors can progress from laboratory demonstrations to clinically meaningful technologies. By integrating material engineering, microfluidic design, and biologically relevant targets, the field is advancing toward robust diagnostic systems that support decentralized, continuous, and patient-centered healthcare.

Dual-Mode (Photo)Electrochemical Enantiomeric Sensing by chiral conductive polymers

V. Pifferi¹, L. Falciola¹, D. Fumagalli¹, W. Aidli¹, S. Arnaboldi¹, S. Grecchi¹

¹ Università degli Studi e UdR INSTM di Milano, via Golgi 19, 20133, Milano, ITALY

e-mail: valentina.pifferi@unimi.it

The discrimination between enantiomers, namely mirror-image molecules that cannot be superimposed, plays an important role in electroanalytical chemistry[1]. Chiral electrochemical sensing can be achieved through different strategies, including the incorporation of chiral components into electrode materials, the use of selective polymeric matrices, or the exploitation of chiral effects arising during electrode modification processes. Among these approaches, the use of inherently chiral molecules has emerged as an effective and versatile strategy, as such systems can provide enantioselective recognition without the need for additional chiral selectors.

Inherently chiral electroactive materials, once deposited on electrode surfaces, have been shown to enable the discrimination and quantification of enantiomers of various chiral compounds[2]. This behavior is commonly attributed to specific interactions between the chiral electrode interface and the analyte during the electron transfer process, which can result in measurable differences in electrochemical responses. In addition, some of these materials exhibit semiconductive and photoactive properties, allowing their use in photoelectrochemical sensing under suitable irradiation conditions.

In this context, hybrid electrode architectures that combine conductive nanostructured materials with chiral and photoactive layers represent a promising platform for advanced sensing applications. The integration of materials with complementary properties can lead to improved electron transfer, enhanced sensitivity, and the possibility of exploiting multiple transduction modes. The use of both electrochemical and photoelectrochemical approaches within a single sensing system offers increased robustness and reliability of analytical measurements, making bimodal sensing strategies[3] particularly attractive for the analysis of chiral analytes.

Acknowledgments: We acknowledge financial support of the Università degli Studi di Milano, Dipartimento di Chimica, PSR Grant.

[1] S. Arnaboldi, et al., *Current Opinion in Electrochemistry*, **2018**, 8, 60–72.

[2] M. Donnici, et al., *Molecules*, **2020**, 25.

[3] W. Aidli, et al., *Current Opinion in Electrochemistry*, **2025**, 50, 101655.

The electrochemical coupling of substituted (pentafluorophenyl)-1,3,4-oxadiazoles via C–F bond cleavage as a new approach for preparation of electron and hole transporters

Matej Uhliar¹, Daniel Végh², Vladimír Lukeš¹, Peter Rapta¹

¹Institute of Physical Chemistry and Chemical Physics, ²Institute of Organic Chemistry and Catalysis and Petrochemistry, Slovak University of Technology in Bratislava, Radlinského 9, SK-812 37 Bratislava, Slovakia

e-mail: peter.rapta@stuba.sk

In this study the synthetical schemes for preparation of 2,5-bis(2,3,4,5,6-pentafluorophenyl)-1,3,4-oxadiazole and its next three new derivatives substituted in the para position with the lateral N,N-diphenylamine and p-tolyloxy moieties is presented. The redox properties of the prepared compounds were investigated using electrochemical and in situ EPR/UV-vis-NIR spectroelectrochemical techniques in anodic and cathodic regions (Figure 1).

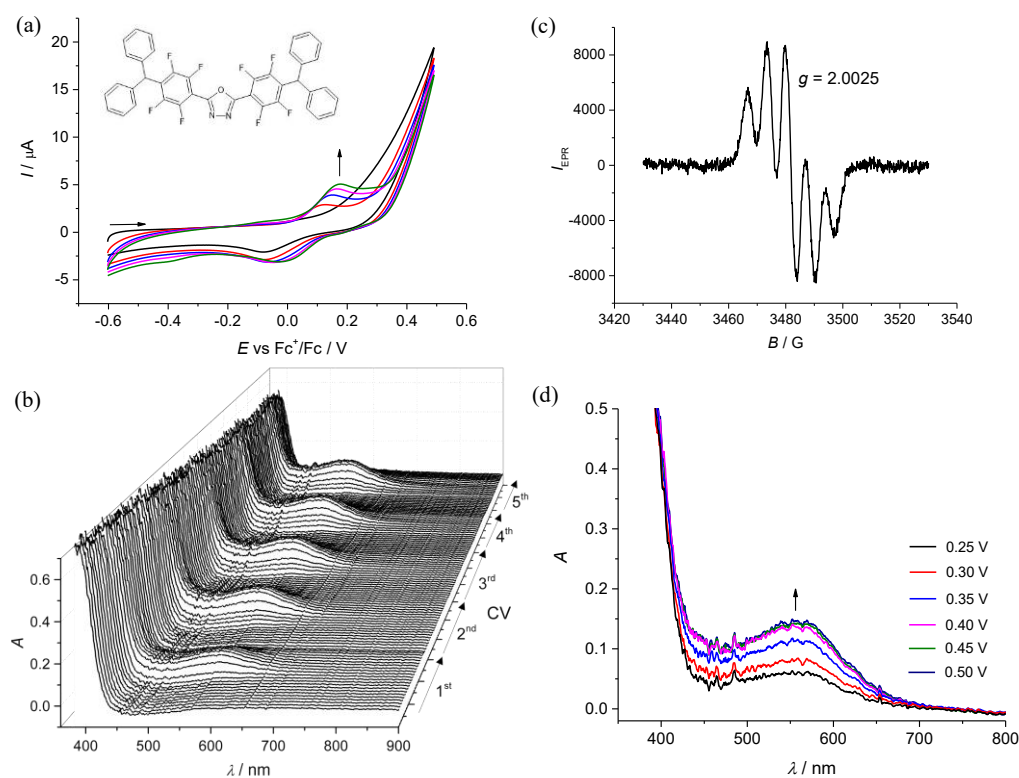

Figure 1. (a) Repetitive in situ cyclic voltammograms of the substituted (pentafluorophenyl)-1,3,4-oxadiazole (see inset) and (b) the corresponding UV-vis-NIR spectra measured during the five CV scans (10 mV s^{-1}) in the anodic region. (c) Representative EPR spectrum measured during in situ reduction and (d) UV-vis-NIR spectra measured during the anodic oxidation of the substituted (pentafluorophenyl)-1,3,4-oxadiazole.

In the anodic part, the formation of dimer oligomer structures via coupling at N,N-diphenylamine moiety was found under formation of benzidine-like structures [1].

In the cathodic part, the formation of new dimeric and/or oligomeric products with an elongated π -conjugation was observed with considerably less negative reduction potentials compared to the initial monomer. The coupling of anion radicals from bis(pentafluorophenyl)-1,3,4-oxadiazoles is accompanied by the release of fluoride anions at different positions on the fluorinated phenyl ring. Similar electrochemical and spectroelectrochemical response was found during the cathodic reduction of all analogues bearing nonsymmetric N,N-diphenylamine and symmetric p-tolyloxy moieties. This indicates that the electrochemical approach can serve as viable option as synthetical method for polymerization of fluorinated compounds [2]. The site of dimerization (Figure 2) and further oligomerization and the mapping of the unpaired spin density for both the corresponding radical anions and the radical cations are interpreted using the quantum chemical calculations performed at the density functional theory level.

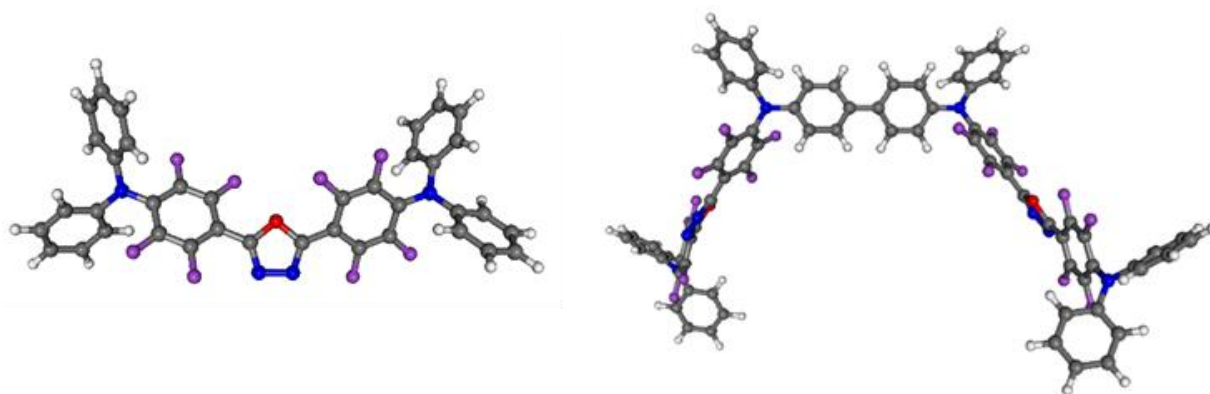

Figure 2. Optimal geometries of the studied substituted (pentafluorophenyl)-1,3,4-oxadiazole and the corresponding dimer in neutral form.

Acknowledgments: The work has been supported by Ministry of Education, Science, Research and Sport of the Slovak Republic (Nos. VEGA 1/0172/25, VEGA 1/0385/25) and by Slovak Research and Development Agency (Nos. APVV-23-0195, APVV-19-0024).

[1] P. Rapta, O. Zeika, D. Rohde, H. Hartmann, L. Dunsch, *Chem. Phys. Chem.*, **2006**, 7, 863–870

[2] M. Uhliar, D. Végh, V. Lukeš, P. Rapta, *Electrochim. Acta*, **2025**, 146229

Water-Processable 2D Covalent Organic Frameworks Based on Porphyrin and Diketopyrrolopyrrole for Advanced Electrochemical Sensing

Alexandru Dron¹, Giuseppe Misia¹, Michael Douglas Pecanha de Souza¹, Giuseppe Borsato¹, Chiara Zanardi^{1,2}, Fabrizio Fabris¹, Alessandro Silvestri¹.

¹Department of Molecular Science and Nanosystems, Ca' Foscari University of Venice, Via Torino 155, Venice, 30172, Italy ²Institute for the Organic Synthesis and Photoreactivity, National Research Council, Bologna, 40129, Italy

e-mail: alessandro.silvestri@unive.it

Covalent Organic Frameworks (COFs) are highly sought-after for their crystallinity, permanent porosity, and structural tunability. [1] However, their inherent lack of processability in aqueous media remains a significant barrier to their integration into analytical devices. In this work, we report the design and synthesis of a novel 2D COF based on porphyrin and diketopyrrolopyrrole (DPP) derivatives. Synthesized via Schiff-base chemistry, the framework utilizes reversible imine linkages to ensure a highly ordered crystalline structure. [2]

To enhance electrocatalytic performance and eco-compatibility, the COF was post-synthetically metalated with non-noble metal salts (MCl_2 , where $M = Co, Fe, Ni, Cu$). Notably, the DPP units were functionalized with carboxylic groups; this strategic modification increases interlayer spacing, facilitating exfoliation and ensuring excellent colloidal stability in water. The electrocatalytic utility of these frameworks was evaluated for healthcare and environmental monitoring. While the pristine COF exhibits intrinsic activity toward H_2O_2 reduction, metalation significantly enhances sensitivity. Furthermore, the Cu-modified COF (CuCOF) demonstrated high sensitivity for direct glucose oxidation (0.1–10 mM) and enabled the detection of glyphosate below the legal limit of 0.1 ppb. These findings highlight the potential of functionalized COFs for water-based inks and the development of low-cost, inkjet-printed disposable sensors.

[1] Ma et al. Approaches and challenges in the synthesis of three-dimensional covalent organic frameworks, *Communications Chemistry*, **2018**, 1, 98.

[2] Geng et al. Covalent Organic Frameworks: Design, Synthesis, and Functions, *Chemical Reviews*, **2020**, 120, 8814-8933.

Next Generation Designs of Voltage/Current Activated Adhesives

T.W.J. Steele¹, K. Lim, R. Webster, A. Ghosh

Affiliation: Nanyang Technological University, wjsteele@ntu.edu.sg

Voltaglue adhesives were first invented by our group in 2015. In the decade since, electrocuring resins have been expanded into biomaterials (catheters and tissue adhesives) and industrial resins based on acrylates and epoxy resins. These novel, one component stimuli sensitive resins address current unmet clinical and industrial applications. Design and improvement of electrocuring resins requires multimodal instruments capable of real-time evaluation under the influence of charge, current, or AC/DC electric fields. Herein, the recent accomplishments and challenges remaining are discussed towards advancing the technology towards advanced manufacturing. Resin development interfaces rheology to electrochemistry, defining how voltage and current control resin properties of viscosity, curing time, and adhesive strength. Case studies of carbene, disulfide, and epoxy resins serve to give the state-of-art progress of the emerging field of electrocuring adhesive platforms.

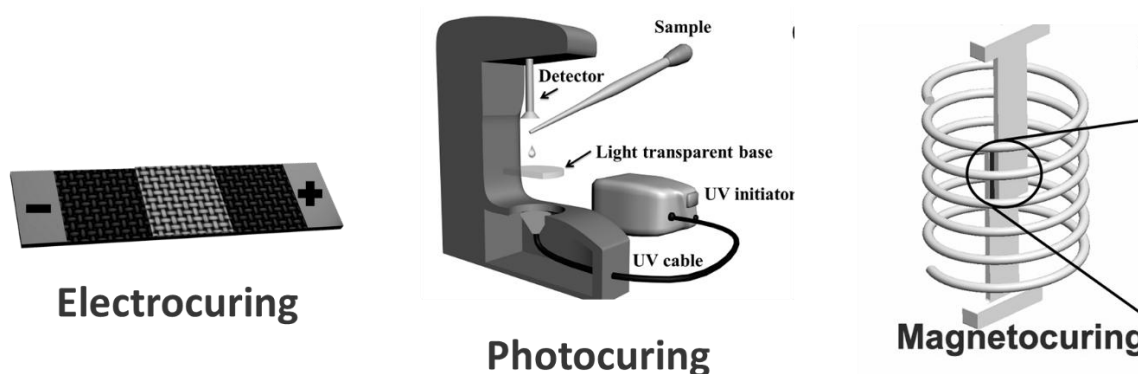

Figure 1: New developments in stimuli sensitive polymers requires advanced rheometry for real-time characterization of liquid and elastic properties.

Manuscripts on electrocuring adhesives, resins, and ‘Voltaglue’

(1) Ghosh, A.; Kozlowski, K.; Steele, T. W. J. Synthesis and Evaluation of Metal Lipoate Adhesives. *Polymers* 2023, 15 (13), 2921.

(2) Ghosh, A.; Meyyappan, P.; Steele, T. W. J. Voltage activation of poly (ethylene glycol) diacrylate. *Progress in Organic Coatings* 2022, 165, 106770. DOI: <https://doi.org/10.1016/j.porgcoat.2022.106770>.

(3) Singh, M.; Varela, C. E.; Whyte, W.; Horvath, M. A.; Tan, N. C. S.; Ong, C. B.; Liang, P.; Schermerhorn, M. L.; Roche, E. T.; Steele, T. W. J. Minimally invasive electroceutical catheter for endoluminal defect sealing. *Sci Adv* 2021, 7 (14), eabf6855. DOI: 10.1126/sciadv.abf6855.

- (4) Ambrosi, A.; Singh, M.; Webster, R. D.; Steele, T. W. J. Precise Control of Diazirine Reduction to Tune the Mechanical Properties of Electrocurable Adhesives. *ChemElectroChem* 2021, 8 (14), 2715-2725. DOI: <https://doi.org/10.1002/celec.202100594>.
- (5) Tan, N. C. S.; Ghosh, A.; Steele, T. W. J. Structure-Activity Relationships of Voltaglu Organic Blends. *Macromol Rapid Commun* 2020, 41 (21), e2000188. DOI: 10.1002/marc.202000188.
- (6) Singh, M.; Yin, C. S.; Page, S. J.; Liu, Y.; Wicaksono, G.; Pujar, R.; Choudhary, S. K.; Kulkarni, G. U.; Chen, J.; Hanna, J. V.; et al. Synergistic Voltaglu Adhesive Mechanisms with Alternating Electric Fields. *Chemistry of Materials* 2020, 32 (6), 2440-2449. DOI: 10.1021/acs.chemmater.9b04962.
- (7) Ghosh, A.; Tan, N. C. S.; Shi, R. R. S.; Webster, R. D.; Steele, T. W. J. Optimizing the Reduction Potential of Sulfonamides on Polyamidoamine Dendrimers. *ChemElectroChem* 2020, 7 (24), 4979-4984. DOI: 10.1002/celec.202001395.
- (8) Singh, M.; Webster, R. D.; Steele, T. W. Voltaglu Electroceutical Adhesive Patches for Localized Voltage Stimulation. *ACS Applied Bio Materials* 2019, 2 (6), 2633-2642. DOI: 10.1021/acsabm.9b00303.
- (9) Gan, L.; Tan, N. C. S.; Gupta, A.; Singh, M.; Pokhonenko, O.; Ghosh, A.; Zhang, Z.; Li, S.; Steele, T. W. J. Self curing and voltage activated catechol adhesives. *Chemical Communications* 2019, 10.1039/C9CC04166D. DOI: 10.1039/C9CC04166D.
- (10) Singh, M.; Nanda, H. S.; O'Rourke, R. D.; Jakus, A. E.; Shah, A. H.; Shah, R. N.; Webster, R. D.; Steele, T. W. J. Voltaglu Bioadhesives Energized with Interdigitated 3D-Graphene Electrodes. *Adv Healthc Mater* 2018, 7 (21), e1800538. DOI: 10.1002/adhm.201800538.
- (11) Gan, L.; Tan, N. C. S.; Shah, A. H.; Webster, R. D.; Gan, S. L.; Steele, T. W. J. Voltage-Activated Adhesion through Donor–Acceptor Dendrimers. *Macromolecules* 2018, 51 (17), 6661-6672. DOI: 10.1021/acs.macromol.8b01000.
- (12) Ping, J.; Gao, F.; Chen, J. L.; Webster, R. D.; Steele, T. W. Adhesive curing through low-voltage activation. *Nat Commun* 2015, 6, 8050. DOI: 10.1038/ncomms9050.

Voltaglu Media Series

- a. [BBC Inside Science, Radio Voltaglu interview.](#)
- b. [Youtube Video : Voltaglu](#)
- c. [Scientists from NTU Singapore find electrifying solution to sticky problem](#) AlphaGalileo
- d. [Scientists find electrifying solution to sticky problem](#) Phys.org
- e. [Electric glue can set anywhere](#) IEEE Spectrum
- f. [Scientists find electrifying solution to sticky problem](#) Materials Today
- g. [Researchers develop glue that works underwater](#) International Business Times
- h. [NTU scientists create electrically charged glue that works underwater](#) TODAY

Electrosensitive Gel Microlayers on Electrode Surfaces

M. Karbarz, M. Sawicka, K. Kaniewska, Z. Stojek

Faculty of Chemistry, University of Warsaw, Warsaw, Poland

e-mail: stojek@chem.uw.edu.pl

Electroactive, electrosensitive, and fast-reacting hydrogel microlayers were constructed on the surface of Au and GC electrodes. The layers consisted of either microgel particles deposited on the gold surface, where poly(acrylic acid), synthesized using distillation precipitation polymerization, was cross-linked with N,N-bis(acryloyl)cystamine (BAC), or the layers were continuous as a result of free radical-induced polymerization of acrylic acid in the presence of methylenebisacrylamide (BIS) at glassy carbon electrodes.

After the deposition of gel layers, Cu(II) ions were introduced and bound to the polymer network due to coordination bonds with the carboxylic groups. Thanks to the reversibility of the electroreduction and electrooxidation of the copper ions (from Cu(II) to Cu(I) and from Cu(I) to Cu(II)), the obtained gel layers could undergo multiple fast swelling and shrinking processes triggered by the application of an appropriate sequence of potentials and changes in the oxidation state of Cu atoms. The obtained gel layers can be applied in the construction of ON-OFF devices and as sensors for the determination of, for example, H₂O₂.

Sustainable Electrode Active Materials for Lithium- and Sodium-Ion Batteries

Monika Wilamowska-Zawłocka¹, Anita Cymann-Sachajdak¹, Jakub Olszewski¹,
Inga Werecka¹, Piotr Madajski², Grzegorz Trykowski², Ievgen Obraztsov³

¹Faculty of Chemistry, Gdańsk University of Technology, Poland; ²Faculty of Chemistry, Nicolaus Copernicus University in Toruń, Toruń, Poland; ³Czech Advanced Technology and Research Institute (CATRIN), Palacky University Olomouc, Olomouc, Czech Republic.

e-mail: monika.wilamowska@pg.edu.pl

The rapid growth of the electrochemical energy storage requires electrode active materials that are high-performing, sustainable, affordable, and resilient to supply chain constraints. This work discusses recent developments in sustainable electrode materials for lithium-ion (LIB) and sodium-ion (SIB) batteries, focusing on the "beyond-lithium" trend and reducing dependence on critical raw materials.

Regarding LIBs, this work focuses on the role of cobalt-containing materials derived from a closed-loop recycling process. It demonstrates how advanced recycling strategies can mitigate the scarcity of critical raw materials and significantly reduce the environmental impact of next-generation LIBs.

Direct recycling restores active electrode materials while preserving their original structure. Compared to conventional pyrometallurgical and hydrometallurgical techniques, direct recycling offers advantages such as lower emissions, fewer by-products, and reduced environmental impact. The work also identifies the key challenges involved in the direct recycling of lithium nickel manganese cobalt oxide (NMC) cathodes and graphitic anodes. Regeneration of cathodes is more challenging due to the polyvinylidene fluoride (PVDF) binder used for water-sensitive materials. The method used to remove the PVDF binder, as well as the method used for re-lithiation, significantly influence the properties of the recovered cathodes, such as their composition, crystal structure, particle size, morphology and impurity content. All of these factors affect the cathodes' electrochemical performance.

Meanwhile, sodium-ion batteries are presented as a promising alternative for large-scale and stationary energy storage due to the abundance and low cost of sodium. This work presents recent developments in sodium-based cathode [2] and anode [3] materials, emphasizing their potential to alleviate resource criticality while enabling sustainable battery technologies.

A naturally occurring and abundant type of brown coal, gogat, can be used as an anode in a sodium-ion battery following a simple one-step low-temperature (500, 700 or 900 °C) pyrolysis process, with no need for chemical purification. The resulting gogat-derived hard carbons (GHC-500, GHC-700 and GHC-900) contain electrochemically active native minerals that enhance electrochemical performance (see Figure 1). Natural S-doping of carbons also improves the capacity values for sodium intercalation. Furthermore, the presence of other inorganic compounds influences the structural evolution of the gogat, transforming it from an amorphous to a turbostratic carbon, and promotes pore formation at

higher temperatures. The resulting GHC samples exhibit an interlayer spacing of approximately 0.39 nm, which falls within the optimal range of 0.37–0.40 nm associated with high-performance hard carbons for Na-ion batteries [3].

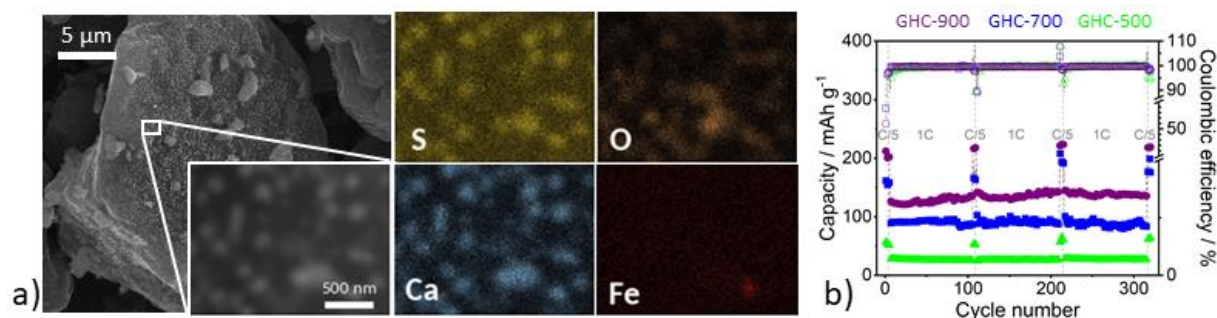

Figure 1. a) SEM-EDX of GHC-900 sample showing inorganic nanoparticles on the surface, b) electrochemical performance of gagat samples pyrolyzed at different temperatures (500, 700 or 900°C) [3].

Although a NASICON-type cathode material ($\text{Na}_3\text{V}_2(\text{PO}_4)_3$, NVP) exhibits high operating voltage and robust structural stability, its practical application is hindered by low electronic conductivity, limited active material and morphology–tap density trade-offs. One way to improve the low electronic conductivity is to coat the NVP particles in carbon. This study presents a simple synthesis strategy that uses a densely carboxylated graphene derivative, graphene acid (GA), as a multifunctional additive. GA functions as a chelating agent, pH regulator and precursor for an in situ-formed carbon coating. This enables the effective reduction of V^{5+} to electrochemically active V^{3+} , the formation of phase-pure NVP and the development of a thin, conformal carbon shell that is strongly anchored to the particle surface. For comparison, NVP was also prepared using a conventional method involving ascorbic acid (AA) as a chelating, and reducing agent, as well as carbon source (NVP@AA). The samples (NVP@GA and NVP@AA) differ significantly in terms of carbon structure, as can be seen in the Raman spectra in Figure 2a). NVP synthesized with graphene acid contains a more ordered carbon component, as evidenced by a more pronounced graphitic G band and a smaller D3 band, which is associated with amorphous carbon. The carbon structure of the composite material substantially influences its electrochemical performance, as shown in Figure 2b). The optimized NVP@GA cathode demonstrates superior rate capability, retaining 65.4% of the theoretical capacity at 15 A g^{-1} and exhibiting stable cycling performance for over 3000 cycles [2].

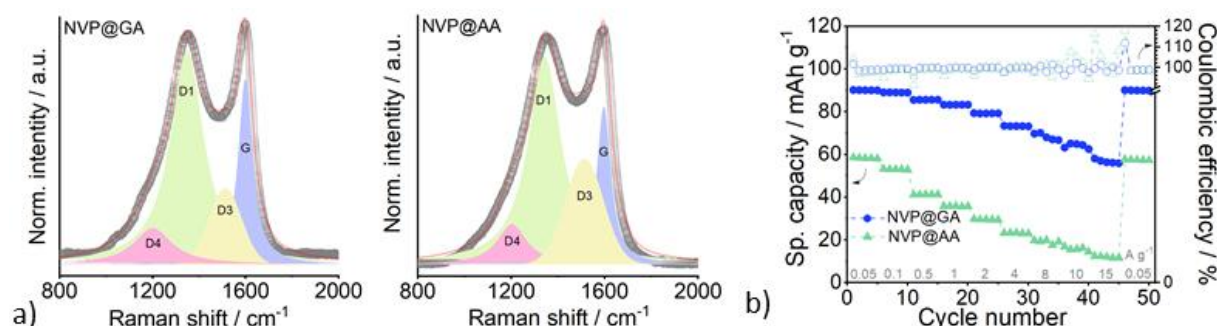

Figure 2 a) Raman spectra of NVP@GA and NVP@AA composites showing different structure of carbon component, b) electrochemical performance of NVP@GA and NVP@AA cathodes [2].

The synthesis approach using graphene acid provides a versatile strategy for the rational design of advanced NASICON cathodes and can be extended to other phosphate-based systems for high-power sodium-ion batteries. Further step to improve sustainability of polyanionic type cathodes is to substitute vanadium to another more abundant transition metal ion.

Overall, this work outlines material design strategies that align electrochemical performance with sustainability, resource efficiency, and circular economy principles. These strategies support the transition toward more robust and responsible battery systems.

Acknowledgments: M.W.-Z. acknowledge the financial support from the National Science Centre, Poland for project "Development of processes for critical raw materials recovery from spent lithium-ion cells", grant no. UMO-2022/46/E/ST8/00395 (SONATA BIS program) and project "Beyond Li-ion batteries: on novel and Efficient electrode materials for Sodium Storage", grant no. UMO-2018/31/G/ST5/02056 (BEETHOVEN CLASSIC 3 program)

[1] Driscoll, L. L.; Jarvis, A.; Madge, R.; Driscoll, E. H.; Price, J.-M.; Sommerville, R.; et al., *Joule* 2024, 8(10), 2735–2754. doi:10.1016/j.joule.2024.07.001.

[2] Obratsov I.; Cymann-Sachajdak A.; Bruniecka K.; Madajski P.; Šedajová V.; Trykowski G.; Bakandritsos A.; Wilamowska-Zawłocka M.; *ACS Applied Materials & Interfaces* 2026, DOI: 10.1021/acsami.5c21272.

[3] Madajski, P.; Obratsov, I.; Cymann-Sachajdak, A.; Wilamowska-Zawłocka, M.; Bakandritsos, A.; Sprynskyy, M.; et al., *Journal of Physics: Energy* 2026, 8(1), 015008. doi:10.1088/2515-7655/ae1e2b.

Oxygen Evolution Reaction and its Competition with Chlorine Oxidation Reaction on Electrode/Electrolyte Interfaces

Yao Yao¹, Minhua Shao²

¹ School of Sciences, Great Bay University, Dongguan 523000, China,

² Department of Chemical and Biological Engineering, The Hong Kong University of Science and
Technology, Clear Water Bay, Kowloon, Hong Kong, China

e-mail: yaoyao@gbu.edu.cn

Nickel (Ni)-based electrocatalysts show excellent performance for oxygen evolution reaction (OER) in alkaline electrolytes. However, their active site structure evolution and degradation mechanisms remain debated over the past decade, especially across a wide range of current densities and applied potentials. In direct seawater splitting, competition from the chlorine oxidation reaction (COR) further complicates mechanistic and kinetic studies of OER. Additionally, the degradation mechanism of active sites in Ni-based electrocatalysts under COR competition conditions remains unrevealed. In this study, we use rotating ring and disk electrode (RRDE) and in-situ Raman spectroscopy techniques to examine electrode/electrolyte interfaces during OER of various electrodes across a wide interfacial pH range, uncovering mass transfer, kinetics, and interface behavior during the competition between OER and COR. (Figure 1) Main findings include: (1) In an alkaline electrolyte, mass transfer of OH⁻ significantly affecting OER performance. (2) NiOOH, the active site for OH⁻ oxidation on Ni, its coverage affected by both applied potential and bulk electrolyte pH. (3) Cl⁻ in the electrolyte attacks NiOOH, reducing its coverage to zero and diminishing OER performance and stability, especially when the electrode/electrolyte interface becomes neutral/acidic. Based on this work and our previous work, we have an enhanced understanding of electrode/electrolyte interfaces during water splitting. [1, 2, 3]

Acknowledgments: This work was supported by Open Fund of the China Spallation Neutron Source Songshan Lake Science City (KFKT2023B15) and Guangdong Basic and Applied Basic Research Foundation (2023A1515110629) for financial support.

[1] Y. Yao, J. Xu, M. Shao, *ACS Electrochem.* **2026**, 2, 2, 519–528,

[2] Y. Yao, J. Xu, M. Shao, *Chin. J. Catal.* **2025**, 73, 271-278.

[3] Y. Yao, E. P. Delmo, M. Shao, *Angew. Chem. Int. Ed.* **2025**, 64, e202415894.

From Oxide to Sulfide via Polymer Composites: A Progressive Strategy towards High-Energy-Density Lithium Batteries

H.Y. Yuan¹, T. Huang¹, A.S. Yu¹

¹Fudan University, Shanghai, China

e-mail: asyu@fudan.edu.cn

Electrode-electrolyte interfacial incompatibility is a major challenge limiting the practical application of all-solid-state lithium batteries. To address this issue, a progressive design of composite solid-state electrolytes was developed, bridging oxide- and sulfide-based systems through polymer-assisted structures.

We first employed in-situ thermal polymerization to fabricate a LAGP-based composite electrolyte, in which the incorporation of oxide filler notably enhanced ionic conductivity and Li⁺ transference number, while expanding the electrochemical stability window to 4.68 V.^[1] Building on this, a double-layer Janus solid electrolyte was constructed, integrating an oxidation-tolerant polymer layer at the cathode side and a flexible polycarbonate interfacial buffer at the Li anode.^[2] This bilayer design effectively mitigated side reactions and interfacial impedance, yielding excellent cycling stability (70% retention after 100 cycles at 0.2 C).

To further enhance ionic transport and interface compatibility, we introduced a sulfide-based argyrodite phase and nano-alumina dual fillers into a copolymer matrix via in-situ polymerization.^[3] The synergistic effects of sulfide–polymer and oxide–polymer interfaces prolonged stability over 1000 h in lithium symmetric cells. Finally, a polymer-coated sulfide composite electrolyte was prepared using a combined wet ball milling and in-situ polymerization process.^[4] The resulting polycarbonate-coated Li_{5.5}PS_{4.5}Cl_{1.5} exhibited a dense, void-free microstructure with an exceptional interfacial stability over 2000 h.

This systematic evolution from oxide–polymer to sulfide–polymer systems reveals the crucial role of interfacial engineering in balancing ionic conductivity, mechanical flexibility, and electrochemical stability. The results provide a coherent strategy for designing next-generation composite solid electrolytes with both high performance and practical processability.

Acknowledgments: This work was supported by the Science and Technology Commission of Shanghai Municipality (no. 2024ZDSYS02), China.

[1] C.H. Tian, M.Y. Song, J.T Tang, et al. *ACS Applied Materials & Interfaces*, **2023**, 16, 1535–1542.

[2] C.H. Tian, M.Y. Song, H.Y Yuan, et al. *Journal of Power Sources*, **2024**, 613, 234920.

[3] H.Y Yuan, C.H. Tian, M.Y. Song, et al. *Journal of Energy Chemistry*, **2024**, 91, 628–636.

[4] H.Y Yuan, W.J. Lin, C.H. Tian, et al. *Nano Energy*, **2024**, 128, 109835.

New Electroactive Materials for the Detection of Glyphosate

M. D.P. Souza¹, G. Moro¹, K. T. Polisel¹, M. Rahimihaghighi¹, D. Massari¹, M. Melucci², M. Gigli¹, A. M. Stortini¹, C. Zanardi^{1,2}

¹*Department of Molecular Sciences and Nanosystems, Ca' Foscari University of Venice, Venezia, Italy*

²*Institute for Organic Synthesis and Photoreactivity, National Research Council, Bologna, Italy*

e-mail: chiara.zanardi@unive.it

1. Introduction

Glyphosate (GLY) is an herbicide globally diffused in water due to widespread use. Given its classification as a probable human carcinogen by the International Agency for Research on Cancer (IARC), its detection by portable and in-situ monitoring techniques is of outmost importance. It can be achieved both by stable devices installed in-line or by disposable sensors associated to a simple and possibly automatic sample pre-treatment. The core of the detection is the design of advanced materials that can detect this species with very high sensitivity and low background interference to reach the performance required by regulations.

We have recently reported that amino acid modified graphene oxide (GO-AA) derivatives can be proposed as active materials for the capture and consequent electrochemical detection of GLY in water [1]. In particular, GO-Lysine (GO-Lys) gave the strongest interaction with GLY, outperforming the pristine unmodified material thanks to hydrogen bond and salt bridge interactions.

Despite being effective, this sensor suffers from high potentials required for analyte oxidation and low mechanical stability. Aiming at improving these drawbacks, electroactive materials containing Cu(II) centers included in innovative and biocompatible chitosan-based films are here proposed as sensing elements for detection by an indirect approach [2].

Specifically, this work introduces surface-deacetylated chitin nanocrystals (CsNCs) as a versatile, biobased functional matrix for the realization of sustainable electrochemical sensing elements.

2. Materials and Methods

Chitin nanocrystals (ChNCs) were prepared via acid hydrolysis of shrimp shell-derived chitin [3]. To tune the surface chemistry, a systematic kinetic study of alkaline deacetylation was performed using 12.5 M NaOH. Three specific materials were selected based on the reaction time: CsNCs₂₅, CsNCs₅₀, and CsNCs₇₅ (corresponding to low, intermediate, and near-maximal surface deacetylation, respectively).

The sensors were fabricated by drop-casting 2 μL of the nanocrystal suspensions (35 mg mL⁻¹) onto glassy carbon electrodes (GCE – 2 mm diameter). For GLY detection, GO-Lys and CuSO₄ were incorporated into the suspension.

The morphology of the film obtained after solvent evaporation was characterized by Scanning Electron Microscope (SEM) and Polarized Optical Microscopy (POM), while

electrochemical performance was assessed via Cyclic Voltammetry (CV) and Electrochemical Impedance Spectroscopy (EIS) in 0.15 M Britton-Robinson buffer. For comparison, similar electrochemical tests were also carried out with a commercial amorphous chitosan suspension (CS).

3. Results and Discussion

3.1. Characterization and Self-Assembly

The deacetylation process follows a biphasic kinetic profile, where surface acetyl groups are removed quickly while the crystalline chitin core remains preserved, resulting in a core-shell structure (**Figure 1A**). This modification significantly altered the self-assembly behavior. POM revealed that pristine ChNCs form chiral nematic phases (Bouligand-type ordering), whereas the enrichment of surface amino groups in CsNCs₇₅ suppresses this long-range chiral ordering (**Figure 1B and 1C**, respectively). This transition from a highly ordered to a more disordered, permeable nanostructure is critical for enhancing ionic and electronic accessibility at the electrode interface.

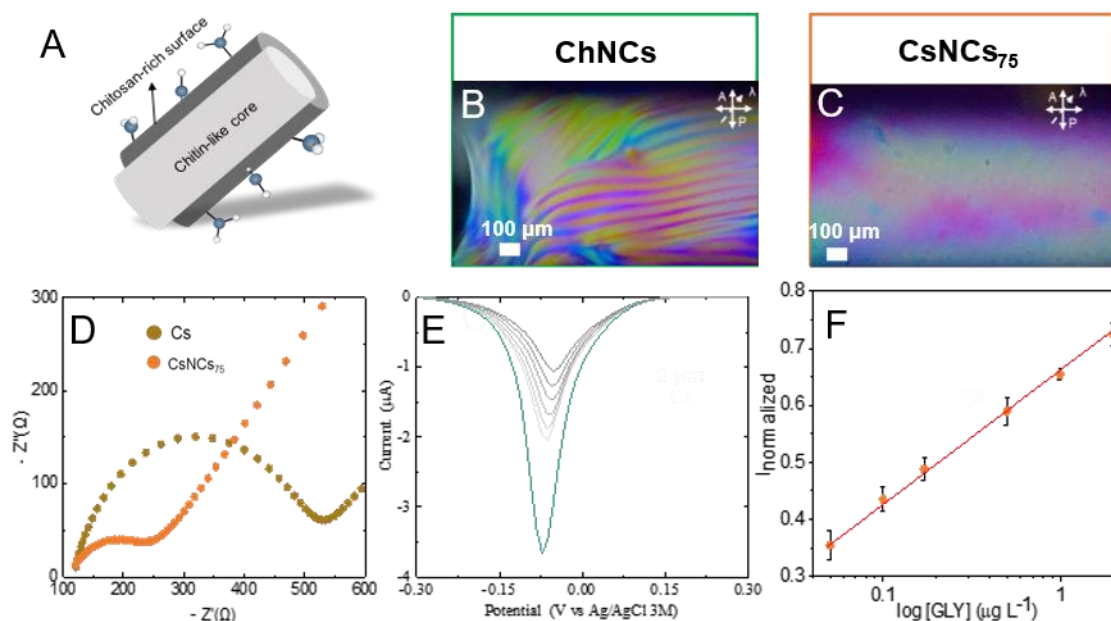

Figure 1. **A**) Schematic representation of the chitosan-rich surface and the chitin-like core. POM images of glass capillaries loaded with suspensions of **B**) ChNCs, and **C**) CsNCs₇₅. **D**) Zoomed-in Nyquist plot recorded in 1:1 2.5 mM ferro/ferricyanide mixture, 0.15 M Britton-Robinson buffer (pH 6) at the open circuit potential. **E**) Calibration response and **F**) Calibration plot reporting the normalized peak current versus the logarithm of GLY concentration in solution.

3.2. Electrochemical Performance

Electrochemical tests using the $[\text{Fe}(\text{CN})_6]^{3-/4-}$ probe showed that CsNCs-based films are highly permeable to ions and exhibit faster electron-transfer kinetics compared to CS. EIS confirmed that interfacial charge transport improves with increasing deacetylation degree: CsNCs₇₅ displayed the lowest charge-transfer resistance ($R_{\text{ct}} \approx 200 \Omega$), compared to ChNCs ($R_{\text{ct}} \approx 700 \Omega$) (**Figure 1D**). This effect can be ascribed to the combination of high the density of amine moieties and of the nanostructured morphology, which provides a more accessible pathway for redox species.

3.3. Glyphosate Detection and Sustainability

The CsNCs₇₅ platform was applied for the indirect detection of GLY at pH 6. The polycationic nature of the film due to the presence of GO-Lys promotes the accumulation of anionic GLY close to the electrode surface, which forms stable complexes with the Cu(II) ions. This interaction results in a decrease of the copper reduction currents, which was correlated to the concentration of GLY in solution. The sensor achieved a limit of detection (LOD) of 0.28 ng L⁻¹ with a linear range between 0.05 and 2.0 µg L⁻¹ (**Figure 1E**). A key feature of the sensing element used is its "peel-and-reuse" capability: the biodegradable film can be mechanically delaminated from the electrode after use, allowing for rapid transducer recovery and reuse with minimal waste.

4. Conclusions

Surface-deacetylated chitin nanocrystals derived from seafood waste represent a high-performance, sustainable alternative to traditional sensing materials. By controlling deacetylation kinetics, we obtained a CsNCs₇₅@GO-Lys-Cu(II) interface that outperforms both pristine chitin and bulk chitosan in terms of charge transfer and sensitivity. The platform provides a robust, regulatory-relevant tool for GLY monitoring while supporting circular economy principles through its recoverable film architecture.

Acknowledgments: the research activities were supported by the European Union Next-GenerationEU - National Recovery and Resilience Plan (NRRP) - MISSION 4 COMPONENT 2 of the "Interconnected Nord-Est Innovation Ecosystem" (iNEST - N. ECS00000043 - CUP N. H43C22000540006).

- [1] G. Moro, S. Khaliha, A. Pintus, S. Mantovani, M. Feltracco, A. Gambaro, T. D. Marforio, M. Calvaresi, V. Palermo, M. Melucci, C. Zanardi. *Materials Today Chemistry*, **2024**, 36, 101936A.
- [2] S. Wang, Y. Yao, J. Zhao, X. Han, C. Chai, P. Dai *RSC Advances*, **2022**, 12, 5164–5172.
- [3] A. G. B. Pereira, E. C. Muniz, Y.-L. Hsieh, *Carbohydrate Polymers* **2014**, 107, 158.

Materials for photo(electro)generation of hydrogen - graphitic carbon nitride (g-C₃N₄) doped with cobalt or nickel

Kamila Zarębska¹, Marcin Maliński¹, Stanisław Olczakowski¹, Magdalena Skompska¹

¹ Faculty of Chemistry, University of Warsaw, Warsaw, Poland

e-mail: kzarebska@chem.uw.edu.pl

Graphitic carbon nitride (g-C₃N₄) is one of the most promising materials for photocatalytic processes. At pH=7, the electronic band potential of g-C₃N₄ is defined as about 1.38 V vs NHE – valence band; and as about -1.52V vs NHE – conduction band (determined by electrochemical method) [1]. Such locations enable the use of g-C₃N₄ as a photocatalyst for redox reactions, including the photodecomposition of water. Its energy bandgap (2.8 eV) allows the absorption of light with wavelengths in the range below 440 nm. However, the photocatalytic activity of pure g-C₃N₄ can be improved using various approaches modifying the electronic structure of the material, for example, by doping.

One possibility is to introduce transition metals with an unfilled *d* subshell into the voids of the g-C₃N₄ layer. This metal is stabilized by the lone pairs of electrons from nitrogen atoms in the triazine units that make up the layer. A coordination bond is formed by sharing the nitrogen electrons with the empty *d* orbital of the transition metal. The presence of such species also increases the number of carriers, as it increases the range of visible light absorption. Additionally, they can provide new active sites for photocatalyzed redox reactions occurring on the semiconductor surface [2].

Therefore, in this work, we studied the influence of doping of g-C₃N₄ by nickel or cobalt. According to the literature, in the presence of Ni or Co atoms an internal electric field is created at the polymer/metal interface, due to electron flow from g-C₃N₄ to metal to equalize the Fermi levels of these two materials [**Error! Bookmark not defined.**]. This enables better carrier separation after light absorption in g-C₃N₄, hindering their recombination and improving the photocatalytic activity of the composite. The obtained composites were characterized using various methods: UV-Vis and IR spectroscopy, scanning electron microscopy (SEM), and powder X-ray diffraction (XRD). The measurements revealed differences between pure and modified g-C₃N₄ and their potential impact on photocatalytic efficiency. The photocatalytic and electrocatalytic properties of the synthesized materials were studied by (photo)generation of hydrogen from water.

Obtained results are promising for using this materials in hydrogen generation.

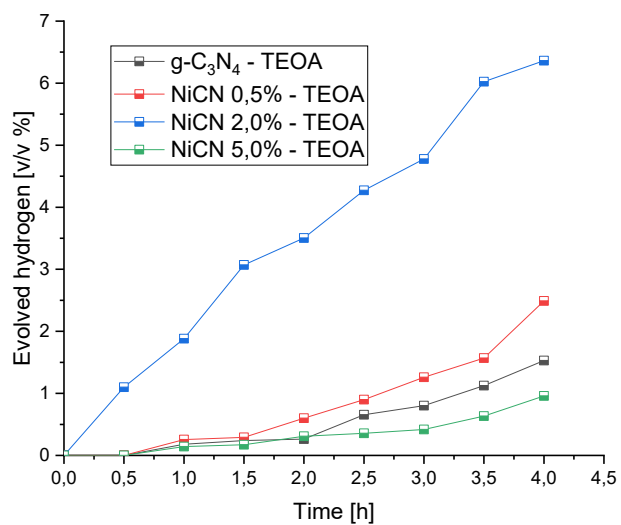

[1] E. Wierzyńska, M. Pisarek, T. Łęcki, M. Skompska, *Molecules*, **2023**, 28(6).

[2] N. Fajrina, M. Tahir, *International Journal of Hydrogen Energy*, **2019**, 44(2) 540-577.

Decoupling the Interfacial Failure Mechanisms of Zn Anodes via Functional Zoning Strategy

Guolang Zhou¹, Lili Zhang¹

¹Huaiyin Normal University, Huai'an 223001, P. R. China

e-mail: zll@hytc.edu.cn

The commercialization of aqueous zinc-ion batteries is impeded by the dynamic interfacial instability of zinc anodes [1]. Conventional homogeneous interfacial layers fail to decouple these conflicting requirements. Inspired by biological compartmentalization, this study proposes a molecular-level functional zoning strategy, employing [2-(9H-carbazol-9-yl) ethyl] phosphonic acid (2PACz) to construct a self-assembled interface layer [2]. This design assigns distinct functions to specific molecular domains: the phosphonate group provides strong anchoring for dendrite suppression; the hydrophobic carbazole moiety blocks water and facilitates desolvation to inhibit HER; while the alkyl chain promotes ordered ion transport channels. This synergistic effect breaks the vicious cycle of interfacial degradation, reducing interfacial water density by 12% and H₂ generation by 43%. Consequently, the Zn||Zn symmetric cell achieves exceptional stability over 4000 hours at 1 mA cm⁻² and 17.1% DOD, and the Zn||MnO₂ full cell maintains 83.1% capacity after 3000 cycles at 3 A g⁻¹. This work provides a novel interfacial design and a universal molecular paradigm for advanced metal anodes.

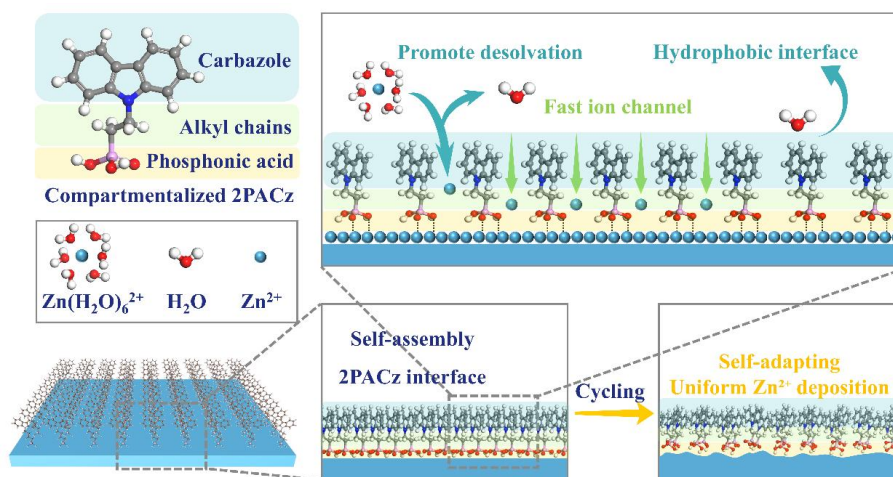

Scheme 1. Schematic diagram illustrating the functional zoning mechanism of the 2PACz interfacial layer.

Reference

- [1] P. Cao, M. Wu, C. Chen, C. Li, C. Luo, H. Zhu, J. Yang, J. Ning, S. Li, *Adv. Energy Mater.* 2025, 15, 2404591
- [2] L. Li, R. Zhang, L. Chen, X. Tian, T. Li, B. Pu, C. Ma, X. Ji, F. Ba, C. Xiong, Y. Shi, X. Mi, J. Li, J. D. Keasling, J. Zhang, Y. Liu, *Adv. Sci.* 2022, 9, e2203652

Chapter 3: Poster presentations

Authors:

Jorge Correia
Eleni Alejandra Cruz-González
Salvatore Daniele
Marius Engler
Marilia Goulart
Dafne Sarahia Guzmán-Hernández
Christian Hoess
Chiydem Hyusein
Zvonimir Katancic
Gabrijela Ljubek
Vladimir Mirsky
Maria-Anthoniette Onoriode-Afunezie
Eleonora Pargoletti
Ralitsa Peneva
Sonya Petrova
Valentina Pifferi
Pulido Quintero
Anna Secundo
Michael de Souza

PEDOT:Cyclodextrin-Quinone Polymers for Sodium-Ion Batteries

Katherine S. Bettencourt,^{1,2} Rui S. Sampaio,² Luis F. Santos,² Ana C. Ribeiro,³ Artur J. M. Valente,³ Jorge P. Correia,¹ Ana S. Viana¹

¹ Centro de Química Estrutural-IMS, Departamento de Química e Bioquímica, Faculdade de Ciências da Universidade de Lisboa, Campo Grande, 1749-016 Lisboa, Portugal, ² Centro de Química Estrutural-IMS, Departamento de Engenharia Química, Instituto Superior Técnico, Universidade de Lisboa, Av. Rovisco Pais, 1049-001 Lisboa, Portugal, ³ CQC-IMS, Department of Chemistry, University of Coimbra, Coimbra, Portugal
e-mail: jorge.correia@fc.ul.pt

The commercialization of lithium-ion batteries (LIBs) has permanently transformed the consumer electronics market, making these devices an integral part of daily life, from mobile phones to laptops [1]. Moreover, their use as support in renewable energy infrastructures and in the automotive sector has further driven their large-scale production [2]. Despite its strong performance, the widespread use of LIBs has proven to be less sustainable than initially expected [3]. Thus, improving recycling processes and developing other battery chemistries has become essential to support sustainable energy infrastructures.

With this in mind, sodium-ion batteries (SIBs) naturally emerge as a promising alternative. Their geographical abundance and chemical similarity to lithium make them attractive for energy conversion [4]. However, the larger size of sodium and different electrochemical behavior from lithium leads to different interactions with their host structures, compromising the overall lifetime and performance of the battery [5]. For instance, a critical challenge in SIBs cathodes are side reactions during cycling, leading to the structural collapse of the material, particularly in crystalline inorganic compounds [6]. As such, rethinking the design of cathode materials plays a central role in their performance.

In this context, organic-based cathodes have emerged as a promising alternative. These materials offer low cost, ease of modification, and structural flexibility for ion incorporation [7]. Among them, compounds containing carbonyl groups and conducting polymers stand out, showing good cycling performances. Moreover, the complementarity between these two classes of materials enables the development of hybrid cathodes with good specific capacity, enhanced stability, and high potentials [7,8]. Nevertheless, their development remains at an early stage, exhibiting lower specific capacities than common inorganic cathodes [7].

As an initial approach to integrate the versatility of carbonyl-based compounds and conducting polymers, we electrosynthesized a copolymer from dopamine (DA) and (3,4-ethylenedioxythiophene) (EDOT) (**Figure 1**). The formation of the PDA/PEDOT copolymer was studied under various applied potentials, electrolytes, and monomer ratios to optimize its performance as a cathode material. Moreover, its physicochemical characterization confirmed the successful synthesis of a hybrid material, with the pseudocapacitance of PEDOT and the quinone/catechol redox activity of PDA. When tested as a cathode material, the copolymer showed a capacity retention of 80% after 2500 half-cell charge-discharge cycles under a current density of 4 mA cm⁻².

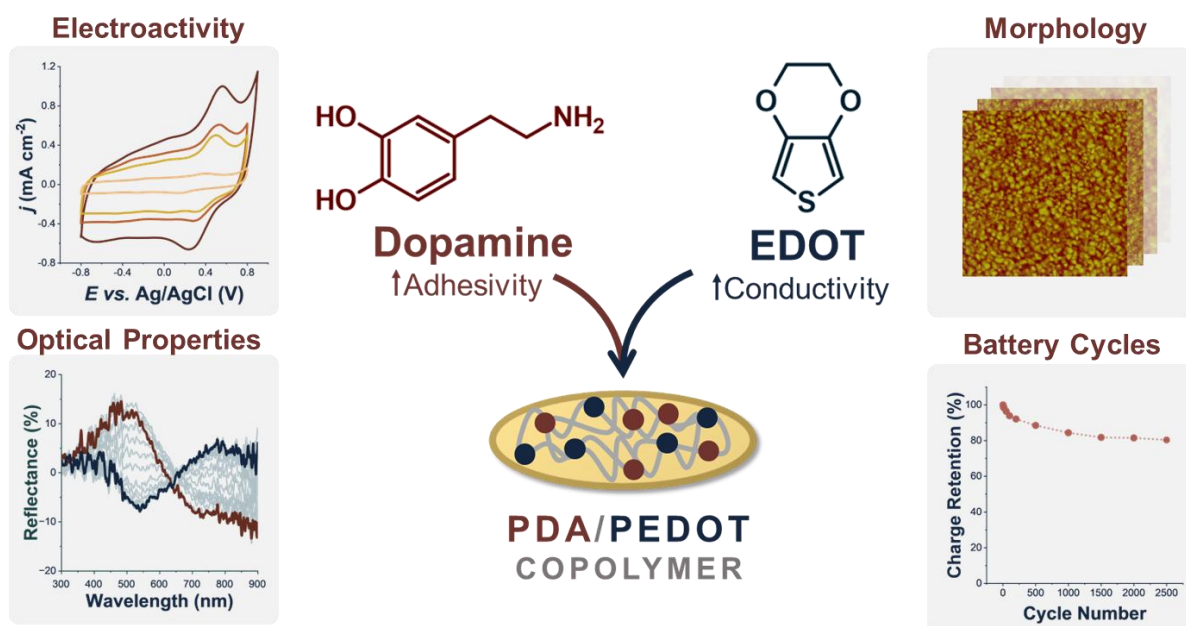

Figure 1 – PDA/PEDOT copolymer cathode material for sodium-ion batteries and characterization methods.

These successful studies have drawn our interest toward other carbonyl compounds, as most reported battery applications rely on para-quinones (e.g., anthraquinone) [9], which can accommodate two sodium ions per unit. However, the chelating nature of ortho compounds remains largely unexplored and may offer advantages for sodium incorporation by providing stronger binding affinities, raising a fundamental question: *how does the position of the quinone moiety influence sodium uptake?*

To answer this question, we electrosynthesized two additional copolymer materials from the monomers catechol and hydroquinone, also combined with EDOT. Nonetheless, immediate differences in reactivity were observed between ortho- and para-quinones, as hydroquinone is significantly less incorporated into the copolymer when electrosynthesized in aqueous solutions. To avoid the use of organic solvents for the incorporation of hydroquinone[10], we decided to stabilize the quinone units of dopamine, catechol, and hydroquinone using cyclodextrin sulfates to form host-guest structures, which can also act as dopants for the conducting polymer.

Thus, the work also focuses on the electropolymerization of hybrid PEDOT:Cyclodextrin-quinone materials. Initially, the interactions between the cyclodextrin adducts and quinones were studied using UV-vis spectroscopy, NMR, and cyclic voltammetry. These adducts were then directly electrosynthesized with PEDOT, and the resulting materials were characterized using electroanalytical techniques, including cyclic voltammetry, electrochemical quartz crystal microbalance (EQCM), and electrochemical impedance spectroscopy (EIS), complemented by AFM, ellipsometry, NMR, and in situ UV-vis reflectance spectroscopy, to elucidate structure-electronic property relationships and their influence on ion uptake.

Acknowledgments: This work was financially supported by Institute of Molecular Sciences LA/P/0056/2020 (<https://doi.org/10.54499/LA/P/0056/2020>) and Centro de Química Estrutural UID/00100/2025 (<https://doi.org/10.54499/UID/00100/2025>), UID/PRR/00100/2025 (<https://doi.org/10.54499/UID/PRR/00100/2025>) and UID/PRR2/00100/2025 (<https://doi.org/10.54499/UID/PRR2/00100/2025>) funded by national funds through FCT/MECI (PIDDAC).

- [1] A. Yoshino, *Angewandte Chemie International*, **2012**, 51, 5798–5800.
- [2] P. Gupta, S. Pushpakanth, M. Haider, S. Basu, *ACS Omega*, **2022**, 7, 5605–5614.
- [3] G. Harper, R. Sommerville, E. Kendrick, L. Driscoll, P. Slater, R. Stolkin, A. Walton, P. Christensen, O. Heidrich, S. Lambert, A. Abbott, K. Ryder, L. Gaines, P. Anderson, *Nature*, **2019**, 575, 75–86.
- [4] J.-Y. Hwang, S.-T. Myung, Y.-K. Sun, *Chem. Soc. Rev.*, **2017**, 46, 3529–3614.
- [5] S.-W. Kim, D.-H. Seo, X. Ma, G. Ceder, K. Kang, *Advanced Energy Materials*, **2012**, 2, 710–721.
- [6] J. Xiao, X. Li, K. Tang, D. Wang, M. Long, H. Gao, W. Chen, C. Liu, H. Liu, G. Wang, *Mater. Chem. Front.*, **2021**, 5, 3735–3764.
- [7] H. Zhang, et al. *Adv. Funct. Mater.*, 2022, 32 (4), 2107718.
- [8] D.R. Santos, J.F. Zeferino, A.S. Viana, K.G.U. Wijayantha, K. Lobato, J.P. Correia, *Eletrochimica Acta*, **2025**, 518, 145760.
- [9] M. Sterby, R. Emanuelsson, X. Huang, A. Gogoll, M. Strømme, M. Sjödin, *Electrochimica Acta*, **2017**, 235, 356–364.
- [10] A.I. Volkov, A.S. Konev, E.V. Alekseeva, O.V. Levin, *J. Mater. Chem. A*, **2025**, 13, 18503–18517.

Electrochemical Nucleation and Growth of Gold Particles on Carbon Paste Electrodes in a Deep Eutectic Solvent.

E. A. Cruz-González¹, D. S. Guzmán-Hernández¹, A. Rojas-Hernández¹, M. Palomar-Pardavé², S. Corona-Avendaño², M.T. Ramírez-Silva¹, M. Romero-Romo².

¹Universidad Autónoma Metropolitana Iztapalapa, CDMX, Mexico, ²Universidad Autónoma Metropolitana Azcapotzalco, CDMX, Mexico.

e-mail: elenialejandra@gmail.com

In this work, the electrochemical modification of a carbon paste electrode (CPE) using a gold salt dissolved in a deep eutectic solvent (DES) known as *Reline* is presented. A cyclic voltammetry (CV) study was carried out, in which the oxidation and reduction peaks associated with the Au⁰/Au³⁺ redox couple are observed, as well as the characteristic equilibrium potential of this metal. The mass transport of gold from *Reline* toward the CPE is determined to be diffusion-controlled. The modification of the CPE surface was performed through metal electrodeposition by chronoamperometry, since one of the main advantages of DES is their ability to facilitate metal deposition processes with high current efficiencies [1]. The mechanism and kinetics of electrochemical nucleation of gold particles on the CPE were evaluated at different overpotentials and deposition times in order to obtain the most efficient surface modification. It is worth noting that *Reline* does not exhibit significant electrochemical activity on the CPE at the applied overpotentials; therefore, no interference with the electrochemical activity of the metal on the electrode surface is observed. The assembly of Au particles on the CPE occurs via a three-dimensional (3D) nucleation process, which is attributed to three main contributions: mass-transport-controlled growth, Au adsorption during the initial stages, and the reduction of residual water [2]. Fundamental parameters such as the diffusion coefficient and the density number of active nucleation sites were determined, showing an increase as the applied overpotential decreases. Finally, the Au-particle-modified CPE was evaluated for the quantification of the anticancer drug 5-fluorouracil, and its analytical performance parameters were obtained. These results demonstrate that this surface modification enables the determination and quantification of pharmaceutical compounds.

Acknowledgments: EACG acknowledges SECIHTI for the scholarship granted for postgraduate studies. DSGH, ARH, MPP, SCA, and MTRS also acknowledge the SNII for the recognition awarded.

[1] A. Abbott, G. Capper, K. McKenzie, K. Ryder, *Journal of Electroanalytical Chemistry*, **2006**, 599, 288.

[2] I. Mejía-Caballero, J. Aldana-González, T. L. Manh, M. Romero-Romo, E. Arce-Estrada, I. Campos-Silva, M. T. Ramírez-Silva, M. Palomar-Pardavé, *Journal of the Electrochemical Society*, **2018**, 165, 393-401

Electrochemistry of the ferric/ferrous system in hydrochloric acid media at Pt microdisk electrodes. Revisiting the effect of adsorbed chloride ions.

Michael D. P. Souza^a, Simone L.D.C. Brasil^b, Chiara Zanardi^a, Salvatore Daniele^a

^a*Department of Molecular Sciences and Nanosystems University Ca' Foscari Venice, Via Torino 155, 30172 Venezia, Italy*

^b*School of Chemistry, Federal University of Rio de Janeiro, Av. Athos da Silveira Ramos, 149, E-206, 21941-909, Ilha do Fundão, Rio de Janeiro, RJ, Brazil*

The electrochemical behavior of the $\text{Fe}^{3+}/\text{Fe}^{2+}$ redox system in HCl solutions is of particular relevance to chemical reactors and the oil and gas industry, where stainless steel and mild steel are widely used as construction materials for pipelines. Hydrochloric acid solutions are commonly employed for pickling operations to remove scale deposits from tubing walls. However, under these conditions, iron corrosion is strongly enhanced, potentially compromising the integrity of metallic components. As a result, significant amounts of metal may be dissolved, and iron ion concentrations in solution can reach several thousand ppm. Although iron corrosion typically initiates with the formation of Fe^{2+} species, Fe^{3+} ions can also be generated in aerated solutions. Consequently, accurate iron speciation is crucial for monitoring corrosion processes and implementing effective mitigation strategies.

The simultaneous identification and quantification of multivalent reversible redox couples in mixtures can rely on the use of steady-state electrochemical techniques, which generates a unique interrelation between current and potential. Thus, in this work, the capability of 25 μm diameter microelectrodes to selectively differentiate Fe^{3+} and Fe^{2+} species, both individually and in mixed solutions, in aqueous 0.5 M HCl was evaluated. Despite the apparent simplicity of the system, the study revealed a previously unreported process associated with the oxidation of Fe^{2+} ion.

Figure 1 shows series of CVs recorded at 10 mV s^{-1} in 0.5 M HCl containing individual Fe^{3+} and Fe^{2+} ions at different concentrations, and initially over the potential region 0.2 – 0.8 V (Figure 1A-C). A close examination of the CV shapes upon varying the iron ion concentrations indicate that the two ions behave differently. In fact, while the reduction process of Fe^{3+} to Fe^{2+} is always characterised by a single well-shaped wave, the oxidation process of Fe^{2+} to Fe^{3+} became more drawn out, while the plateau current is barely approached as the ion concentration increases (Figure 1B-C). Further increasing the Fe^{2+} ion concentration, the onset of an additional oxidation process appeared at about 0.8 V, and fully developed extending the anodic region up to 1.1 V (Figure 1D).

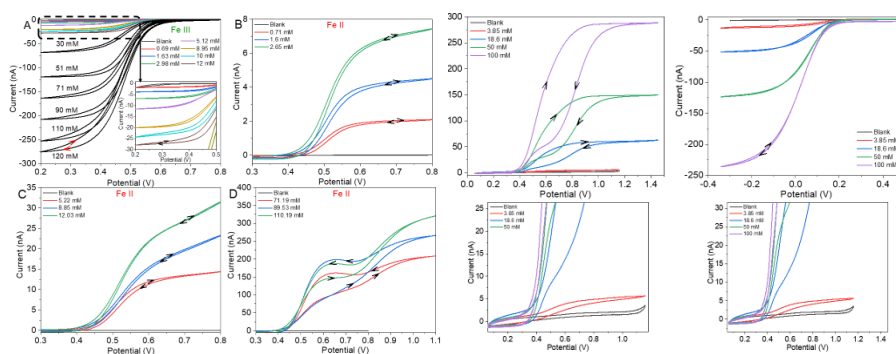

Fig. 1

Fig. 2

To assess the effect of the electrolyte on the voltammetric behavior of the $\text{Fe}^{3+}/\text{Fe}^{2+}$ system, comparative cyclic voltammograms were also recorded in 0.5 M H_2SO_4 with the same Pt microelectrodes and over similar iron ion concentrations (Figure 2). A different wave shapes for the Fe^{3+} reduction and Fe^{2+} oxidation processes were again recorded. Also in this case, a wave split occurred for the Fe^{2+} oxidation at relatively high ion concentration, although with different features. In particular, the wave split was recorded during the backward scan and with lower currents. To explain the above unexpected wave split for the oxidation of Fe^{2+} the following hypothesis were considered.

In HCl solutions, adsorbed Pt oxide/hydroxide species and anionic Pt-chloro complexes are formed in the potential window 0.7 – 1.1 V [1-3]. Furthermore, the adsorbed anionic species can interact with the positively charged free iron ions and iron-chlorine complexes in the solution phase. Therefore, it is likely that the here observed change of the wave shape at higher Fe^{2+} concentration can be due to a combination of sluggish electron transfer and relatively slow adsorption/desorption of the electro active species at/from the electrode surface. This hypothesis is supported by the theory of Laviron [4,5] and Amatore [6], regarding the competitive role between surface and heterogeneous electron transfer associated to kinetically controlled adsorption/desorption reactions [4,5], for RDE voltammetry and more in general for steady-state voltammetry [6].

Considering the H_2SO_4 medium, the different features of the CVs recorded for the oxidation of Fe^{2+} can be essentially associated to the irreversible character of the Pt-Ox formation/reduction, which occurs at less positive potentials, compared to the HCl medium [7].

The voltammetric behaviour of Fe^{3+} and Fe^{2+} in 0.5 M HCl solutions containing equimolar concentrations of both ions is shown in Fig.3. Although the above different behaviours for the reduction and oxidation of Fe^{3+} and Fe^{2+} are confirmed, the two ions can be easily distinguished (Figure 3A) and quantified through the calibration plots (Figure 3B,C), in the latter case using the limiting currents.

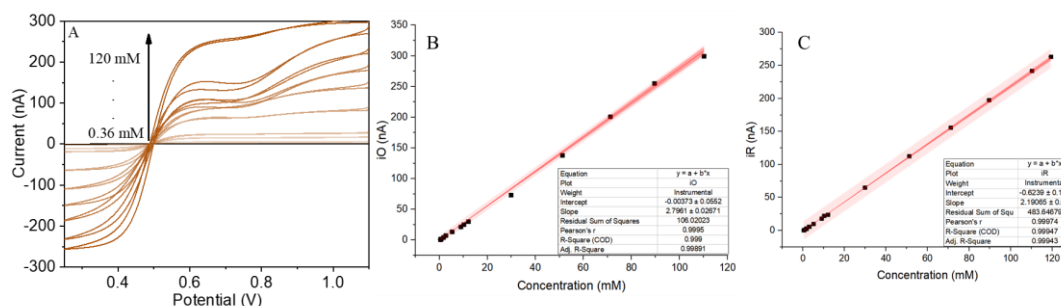

Fig. 3

Finally, to assess the effect of mass transport on the voltammetric behavior of the Fe³⁺/Fe²⁺ redox system, series of CVs were performed in either HCl (Figure 4A) and H₂SO₄ (Figure 4B) solutions containing high iron ion concentrations, at a polished Pt disk electrode of conventional size, where fully planar condition applies. In this case, the classical peak shaped responses in both the positive and negative potential scans (with no wave split) were recorded, regardless the Fe²⁺ concentration and base electrolytes employed.

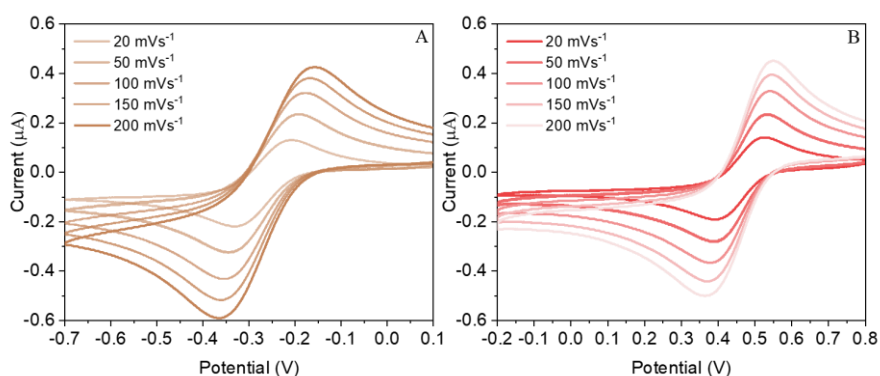

Fig. 4

In conclusion, the above results overall indicated that the Pt surface state, the nature of the adsorbed species, and mass transport conditions significantly affect the reaction path of Fe²⁺ oxidation in both HCl and H₂SO₄ media.

References

- [1] P. P. Lopes, D. Strmcnik, D. Tripkovic, J. G. Connell, V. Stamenkovic, N. M. Markovic, *ACS Catal.* 2016, 6, 2536–2544,
- [2] R. F. Lane, A. T. Hubbard, *J. Phys. Chem.* 79 (1975) 808 – 815.
- [3] Ref S. Gilman, *J. Phys. Chem.* 68 (1964) 2098 – 2111.
- [4] E. Laviron, *J. Electroanal. Chem.* 124 (1981) 19.
- [5] E. Laviron, *J. Electroanal. Chem.* 140 (1982) 247 – 268.
- [6] O. V. Klymenko, I. Svir, C. Amatore, *J. Electroanal. Chem.* 688 (2013) 320–327.
- [7] D. M. Novak, B. E. Conway, *J. Chem. Soc., Faraday Trans. 1*, 1981, 77, 2341–2359.

Strategies to suppress hydrogen evolution during iron plating in all iron redox flow batteries

M. Engler¹, M. Stich¹, A. Bund¹

¹Technische Universität Ilmenau
marius-michael.engler@tu-ilmenau.de

Iron-based redox flow batteries (RFBs) represent a promising technology for energy storage due to their lower costs and environmental benefits compared to other techniques like lithium-ion batteries or electrolyzers [1]. However, a central challenge is the hydrogen evolution reaction (HER) that can occur during the charging process, thereby reducing the efficiency of iron deposition and the overall system performance. Controlling HER is crucial to fully harness the technical and economic advantages of this battery technology [1,2]. This study aims to identify and evaluate effective strategies to suppress HER in order to enhance the efficiency and electrolyte stability for iron RFBs, with a particular focus on the interactions between electrode materials, operating conditions, and especially on electrolyte additives.

Novel approaches discussed in literature provide strategies for the coordination of iron and the selective enhancement of kinetic parameters relative to the HER [3-5]. We conducted a comprehensive analysis and employed various methods for HER suppression. These included the modification of the electrolyte using organic and inorganic additives, and the systematic adjustment of process parameters through optimized experimental designs.

Electrochemical measurements were performed using cyclic voltammetry and potentiostatic plating/stripping cycles in combination with electrochemical quartz crystal microbalance to assess the effectiveness of these strategies. They are complemented by structural analyses of the surfaces.

Our results demonstrate that certain additives (supporting electrolytes and several organic additives) can effectively inhibit HER without adversely affecting iron deposition. Furthermore, water in salt electrolytes could be a promising approach. The optimization of operating conditions, such as electrolyte temperature and pH, helped to reduce the HER.

The developed strategies provide significant advances in enhancing the efficiency and stability of iron RFBs. Modifying the electrode surface and employing specific additives proved particularly effective for HER suppression. These approaches not only improve cell performance but can also extend the battery's lifespan. Further exploration of novel materials for even more efficient HER suppression is also pursued.

[1] G. L. Soloveichik, *Chemical reviews*, **2015**, 115 (20), 11533-11558.

[2] M. Engler, M. Stich, C. Baumer, A. Bund, *J*, **2024**, 7 (4), 571–583.

[3] A. Concheso, et al., *Battery Energy*, **2025**, e20240059.

[4] J. Wan et al., *Journal of The Electrochemical Society*, **2025**, 172 (10), 103503.2025.

[5] N. Sinclair, et al., *Journal of The Electrochemical Society*, **2025**, 172, (6), 062503.

Beyond the Old Scaffold: Inspiring New Medicines from Nitrohetero- aromatic Redox Chemistry

Marília O. F. Goulart¹, Danyelle C. Santos¹, Bruno dos Santos², Thaissa L. Silva², Nicolas Primas³, Roman Paoli-Lombardo, Thierry Terme,³ Alix Saquet,⁵ Pierre Verhaeghe⁴

¹Instituto de Química e Biotecnologia, Universidade Federal de Alagoas, Maceió, AL, Brazil, ²Núcleo de Ciências Exatas – NCEX, Universidade Federal de Alagoas – Campus de Arapiraca, Arapiraca, AL, Brazil, ³Aix-Marseille Université, Marseille, France, ⁴Grenoble Université, France, ⁵LCC-CNRS, Université de Toulouse, France

mariliaofg@gmail.com

An enduring scaffold, nitroaromatic electrochemistry continues to reveal novel redox mechanisms and therapeutic opportunities in medicinal chemistry for tropical diseases. By mapping redox activation and guiding medicinal chemistry, classic scaffolds reveal fresh therapeutic opportunities [1-4].

Due to several emerging new active nitroheterocycles targeting *L. dononavi*, *L. infantum* and *T. brucei*, etiological agents of Visceral Leishmaniasis (VL) and Human African trypanosomiasis (HAT), the interest in nitroimidazole derivatives as anti-trypanosomal agents has drastically increased. The biological activity of these drugs, whether therapeutic or toxic, depends primarily on the reduction of the nitro group and on the stability of the resulting radicals and redox intermediates, particularly the nitro radical anions, in their interactions with cellular components, mainly nitroreductases [3,4]. Since the molecular mechanism of biological action of this group of compounds is not yet fully elucidated, the present work investigated the bioelectrochemistry of highly active trypanocidal and leishmanicidal nitroimidazo[1,2-*a*]pyridines, with good selectivity index (> 50) [5] (Fig.1). Electrochemical studies were performed on glassy carbon electrode (GCE), using cyclic voltammetry (CV) and differential pulse voltammetry (DPV) in protic media (ethanol (20%) + acetate buffer pH 4.23) to resemble the hydrophilic environment of biological matrices and aprotic media (CH₃CN + TBAPF₆ 0.1 mol L⁻¹), to mimic the lipophilic environment of cell membranes. Studies using the dsDNA biosensor were performed to assess whether nitroaromatics and their electrogenerated products interact with dsDNA. All seven compounds studied were electrochemically active in reduction. The VCs showed complex profiles for all seven molecules, with several cathodic waves. For the sulfonated compounds, represented by RPL28 (Fig. 1A) and CF053 (Fig. 1B), the self-protonation mechanism (Fig 1E) was evidenced by 1) the absence of the anodic wave Ia; the absence of cathodic wave Ic in successive scans (Fig. 1B) 2) in the presence of a strong base (TBAOH), a substantial current reduction of Ic (Fig. 1C). Spectroelectrochemical investigation for RPL28 (Fig. 1D), CF166, and CFT050 revealed a decrease in the absorbance of some absorption bands during the application of cathodic potentials, which suggests the reduction of the

nitroaromatic function and formation of its reduction products. No interaction between CF166 and ds-DNA was observed in the studies with the ds-DNA biosensor. Electrochemical and spectrophotometric methods proved suitable for the redox study of nitroimidazo[1,2-a]-pyridines and were correlated with trypanocidal activities, with *Eplc*.

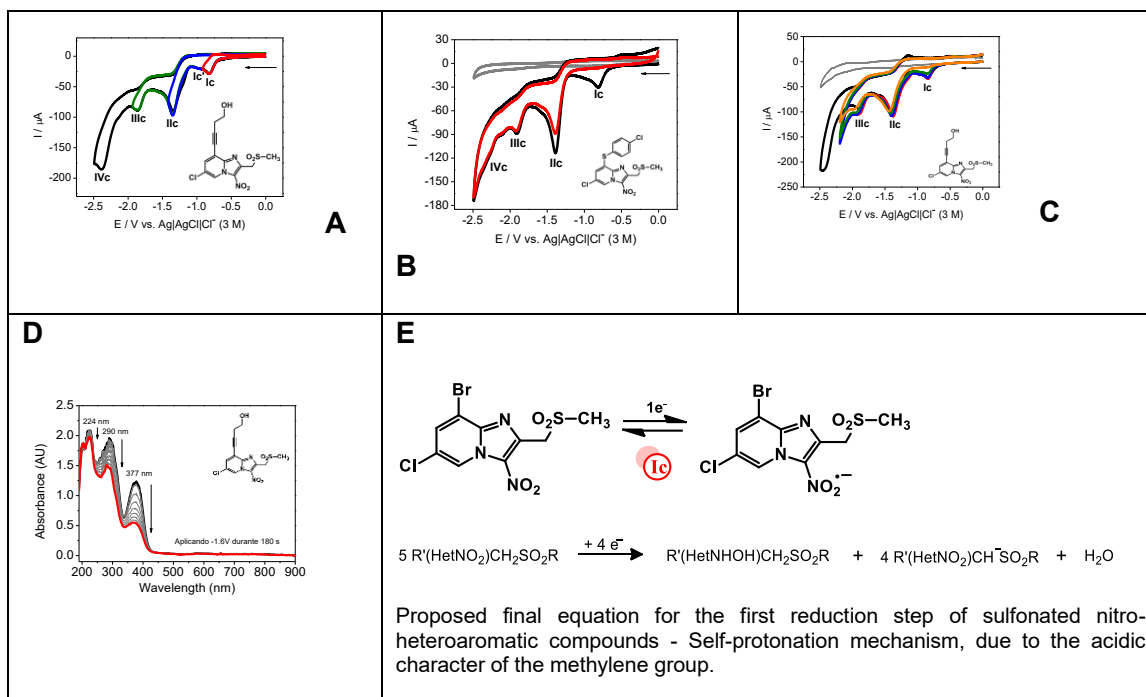

Figure 1: (A) Several inversion potentials in the CV of RPL28 (1 mM) in acetonitrile + TBAPF₆ (0.1 M), GCE, cathodic direction, $\nu = 100 \text{ mV}\cdot\text{s}^{-1}$. (B) Cyclic voltammetry (CV) of CF053 (1 mM). (C) RPL028 + TBAOH: (—) $c = 0,1 \text{ mmol}\cdot\text{L}^{-1}$, (—) $c = 0,2 \text{ mmol}\cdot\text{L}^{-1}$, (—) $c = 0,5 \text{ mmol}\cdot\text{L}^{-1}$, (—) $c = 1 \text{ mmol}\cdot\text{L}^{-1}$ (D) Spectroelectrochemistry (applied potential of -1.6 V) under the same conditions.

Acknowledgements: CAPES, FAPEAL, CNPq, Inctbio-LK, for financial resources.

[1] J. A. Xavier, T. L. Silva, E. C. Torres-Santos, C. C. de Vasconcelos, A. Boane, *Curr. Opin. Electrochem.* 2021, 29, 100740.

[2] R. D. Webster, in *Organic Electrochemistry: Revised and Expanded* (Eds: O. Hammerich, B. Speiser, 5th ed., CRC Press, Boca Raton, FL 2015, pp. 1543–1567.

[3] J. S. Pacheco, D. S. Costa, E. F. Cunha-Júnior, V. V. Andrade-Neto, A. H. Fairlamb, S. Wyllie, M. O. F. Goulart, D. C. Santos, T. L. Silva, M. A. Alves, P. R. R. Costa, A. G. Dias, E. C. Torres-Santos, *ACS Med. Chem. Lett.* 2021, 12, 1405.

[4] Santos, D. C. et al., *ChemElectroChem* 2025, 12, e202500068.

[5] Paoli-Lombardo, R. et al. *Pharmaceuticals* 2022, 15, 998.

Polymer–Chelator Synergistic Effects in Carbon Paste Electrodes for Chromium(III) Detection.

D.S. Guzmán-Hernández¹, M. Palomar-Pardavé², A. Rojas-Hernández¹, S. Corona-Avendaño², M. Romero-Romo², B. González-Estrada¹, M. T. Ramírez-Silva³.

¹Universidad Autónoma Metropolitana Iztapalapa, CDMX, México, ²Universidad Autónoma Metropolitana Azcapotzalco, CDMX, México, ³Sistema Nacional de Investigadores.

E-mail: dsguzman@xanum.uam.mx

Contamination of water bodies associated with the presence of heavy metals represents a significant environmental and public health concern worldwide; among these, Cr(III) is of particular relevance [1]. Although conventional methods for heavy metal detection are effective, their complexity limits their application in routine monitoring scenarios. In this context, the present work focuses on the optimization of a novel methodology for the quantification of Cr(III) in aqueous media using carbon paste electrodes (CPE) modified with chelating and crosslinking agents such as β -cyclodextrin (β -CD), ethylenediaminetetraacetic acid (EDTA), and chitosan (CS). Fig. 1a shows the modification of the CPE surface by cyclic voltammetry (CV) in a 0.01 M β -CD solution prepared in 1 M HClO₄, applying 30 potential cycles within a window from -0.8 to 1.3 V. In the CV of the CPE modified with β -CD (CPE- β -CD), characteristic electrochemical signals can be identified, including anodic peaks O₁, O₂, and O₃ located at 0.5, 0.88, and 1.1 V, respectively, which, according to the literature, are associated with processes involving OH⁻ functional groups. Additionally, cathodic peaks R₁ and R₂ appear at -0.4 and 0.42 V, respectively [2].

Fig. 1b presents successive CVs recorded in a solution containing 0.1 M β -CD, 0.01 M EDTA, and 0.1% low molecular weight CS in 1 M HClO₄, applying 30 potential cycles within a window from -0.8 to 1.3 V. In contrast to the β -CD-only modification, the anodic peak potentials (O₁, O₂, O₃) shift closer together, reducing the potential differences between them, while cathodic peaks R₁ and R₂ are preserved and an additional peak (R₃) appears. This behavior suggests that the observed electrochemical response arises from the interaction among the three components. It is worth noting that β -CD plays a crucial role in the electropolymerization process on the CPE surface. Once electropolymerized, it is likely that the amino groups of CS interact with the β -CD layer through electrostatic interactions, facilitating the formation of a stable and functionalized film. Meanwhile, EDTA acts as a chelating agent, enhancing the interaction with metal ions present in the system by capturing and stabilizing Cr(III).

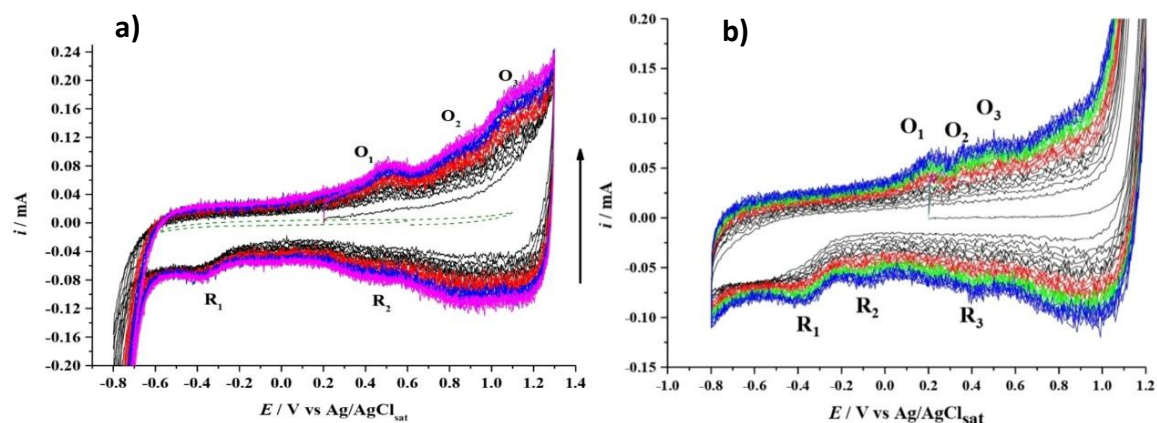

Figure 1. Successive CVs obtained in the electrode/HCl 1 M system with the different electrodes: **a)** the CPE/poly-β-CD and **b)** the CPE/poly-β-CD-EDTA-CS in both cases the potential scan rate was 0.1V s⁻¹.

Fig. 2 depicts the CV response of 3.4 mM Cr(III) at pH 5 on the CPE-β-CD-EDTA-CS (solid green line), where reduction processes corresponding to Cr(III) to Cr(II) and Cr(II) to Cr(0) are observed at 0.12 and -0.11 V, respectively. The synergistic effect of β-CD, EDTA, and CS promotes the formation of a stable modified surface, resulting in an increase in electroactive area and, consequently, an enhancement in current response.

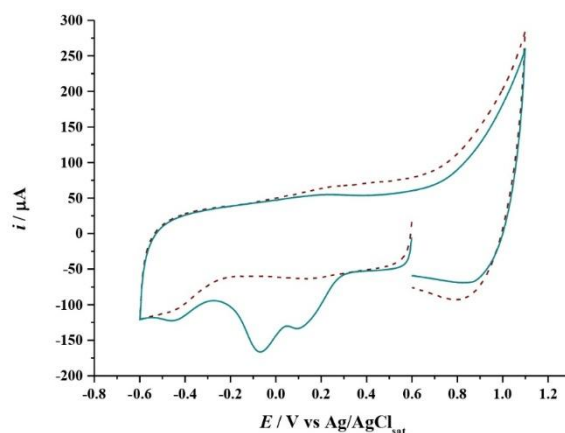

Figure 2: Comparison of experimental CVs obtained in the systems: CPE-β-CD-EDTA-CS / 3.4 mM Cr (III) (solid green line) and CPE-β-CD-EDTA-CS / acetates 0.1 M pH 5 (broken red line). In both cases, the potential sweep started at 0.6 V, in the cathodic direction, at 100 mV s⁻¹.

An analytical study for the determination of Cr(III) was performed using different modified electrodes: CPE-β-CD, CPE-β-CD-EDTA, and CPE-β-CD-EDTA-CS. Fig. 3 shows linear voltammograms (LV) obtained for Cr(III) at different concentrations (0–1.1 mM) using the CPE-β-CD-EDTA-CS electrode. The anodic current peaks observed at 0.1 V (p1) and -0.06 V (p2) are associated with the reduction processes of Cr(III) to Cr(II) and Cr(II) to Cr(0), respectively, as evidenced by their proportional increase with Cr(III) concentration.

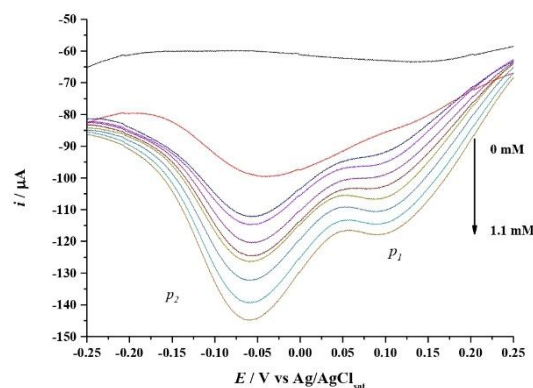

Figure 3: Family of LVs obtained in the system 0.1 M acetate buffer at pH=5, with different Cr (III) concentrations indicated in the figure, using CPE- β -CD-EDTA-CS, the potential sweep started at 0.3 V, in the cathodic direction, at 100 mV s^{-1} .

Table 1 summarizes the analytical performance parameters, including the limit of detection (LOD), limit of quantification (LOQ), and sensitivity towards Cr(III) determination using CPE- β -CD, CPE- β -CD-EDTA and CPE- β -CD-EDTA-CS as working electrodes.

Table 1. Comparison of the analytical performance of the different electrodes considered in this work towards Cr(III) quantification.

Electrode	Sensitivity / $\mu\text{A}\cdot\text{mM}^{-1}$	LOD / mM	LOQ / mM
CPE- β CD	11.2 ± 0.5	0.41 ± 0.16	0.41 ± 0.16
CPE- β CD-EDTA	50 ± 1	0.05 ± 0.02	0.17 ± 0.02
CPE- β CD-EDTA-CS	91 ± 2	0.10 ± 0.04	0.33 ± 0.04

A significant increase in sensitivity is observed after modifying the CPE- β -CD surface. EDTA incorporation enhances sensitivity compared to the CPE- β -CD, while additional chitosan modification leads to an eightfold increase. This improvement is attributed to the larger electroactive surface area and the synergistic effect between the chelating and crosslinking agents, which favors charge transfer.

Acknowledgments: BGE acknowledges SECIHTI for the scholarship granted for postgraduate studies. DSGH, MPP, ARH SCA, MRR and MTRS also acknowledge the SNII for the recognition awarded. The authors also thank the project “Cuerpos de agua en el Estado de México: monitoreo de contaminantes y una propuesta para su eliminación basada en tratamientos biológicos y de oxidación avanzada,” funded under the interinstitutional collaboration framework between UAMEX, IPN, and UAM.

[1] Choppala G., Bolan N., Park J. H. (2013). *Advances in agronomy*, 129-172.

[2] Morales G. R., Silva T. R., Galicia L. (2003). *Journal of Solid State Electrochemistry*, 7(6), 355-360.

Investigation of the formation of active phases on Nickel anodes for enhancing oxygen evolution reaction kinetics for alkaline electrolysis

Christian Elieser Höß¹, Marius Michael Engler¹, Andreas Bund¹

¹*Technische Universität Ilmenau, Germany,
christian-elieser.hoess@tu-ilmenau.de*

The sustainable production of green hydrogen presents a promising pathway to store energy from fluctuating energy sources. Among different techniques such as proton-exchange-membrane electrolysis and solid oxide electrolysis, alkaline water electrolysis using anion exchange membranes seems to be a promising technology due to integration of low-cost catalyst and structural materials like nickel and nickel-based alloys [1,2]. Alkaline water electrolysis is well developed and is demonstrating good long-term stability, making it a suitable candidate for large scale hydrogen production. However, to achieve comparable power densities and efficiencies like the other techniques, it requires further development of cost-effective, highly active and stable catalysts, surface engineering and pretreatment procedures for the formation of active phases at the catalyst layers for the sluggish oxygen evolution reaction (OER).

In the literature on catalyst development, pretreatment procedures are often not systematically investigated. Some papers discussing this issue recommend cyclic voltammetry due to the ability to form larger hydroxide layers which leads to a better activation [3]. In this contribution, we present recent experimental findings on the formation of active nickel phases in 1 M KOH, achieved through different electrochemical methods like immersion pretreatment, chronoamperometry, chronopotentiometry and cyclic voltammetry coupled with electrochemical quartz crystal microbalance (EQCM). This combined approach enables the direct correlation of the surface phase transformations derived from mass changes observed during EQCM, with the variation of the electrochemical pretreatments. These correlations help to elucidate the growth and mechanisms of active phase formation. The kinetic improvement of the OER is investigated with subsequent measurements of linear sweep voltammetry (curve progression, j_0 and Tafel slope) and chronopotentiometry at 10 and 100 mA/cm² (overpotential η_{10} and η_{100}).

Additionally, ex-situ analyses, like scanning electron microscopy, energy-dispersive X-ray spectroscopy, X-ray diffraction and X-ray photoelectron spectroscopy can be carried out to investigate morphology changes and to specify the resulting phases relating to the observed techniques. This combination of techniques allows an extensive investigation of pretreatments for nickel for the OER in alkaline electrolysis, and obtaining an optimized pretreatment for nickel electrodes.

Acknowledgments: This work is funded by the German Federal Ministry for Economic Affairs and Energy (BMWi) with the ZIM project NiProAEM (Funding reference number: 16KN115820) based on a decision of the German Bundestag.

- [1] D. George and R. K. Singh, *Journal of Materials Chemistry A*, **2025**, 13, 38727-38752
- [2] Z. Angeles-Olvera, A. Crespo-Yapur, O. Rodriguez, J. L. Cholula-Diaz, L. M. Martinez and M. Videa, *Energies*, 15, en15051609
- [3] C. Gohlke, J. Gallenberger, N. Niederprüm, H. Ingendae, J. Kautz, J.P. Hofmann, A. K. Mechler, *ChemElectroChem*, **2024**, Volume 11, e202400318

Modification of Carbon Screen Printed Electrodes through combined Deposition of Ag and Cu

Ch. Hyusein, S. Ivanov, V. Tsakova,

Institute of Physical Chemistry, Bulgarian Academy of Sciences, Sofia, Bulgaria

e-mail: chyusein@ipc.bas.bg

In the present study four types of screen printed electrodes (SPEs) – carbon nanofibers (CNF), single-walled carbon nanotubes (SWCNT), mesoporous carbon (MC), and just carbon (C110) were modified by combined deposition of Ag and Cu. Silver nanoparticles were first obtained via spontaneous metal deposition on cathodically pre-treated SPEs. In the absence of solute reductant in the metal plating solution [1].

For the subsequent Cu deposition two techniques were applied: galvanostatic deposition [2] and an immersion-based method. In the latter approach the Ag-modified SPEs were immersed in the Cu plating solution, where Cu ions become adsorbed onto the electrodes surface. In a next step, the adsorbed copper ions are reduced to copper particles by voltammetric electrodeposition in acidic supporting electrolyte. Data for the amounts of both deposited metals were obtained by electrochemical dissolution in acidic solution. The modified electrodes were characterized by means of SEM and EDX analysis.

Comparison between the amount of Cu obtained by the immersion approach on non-modified and Ag-modified SPEs revealed a two-fold decrease of the Cu mass on the Ag-modified ones. Only the CNF SPE demonstrated an exception to this trend, with markedly increased amount of Cu in the presence of Ag. This difference is most likely related to the surface functionalization of the different carbon substrates and its role in both spontaneous Ag deposition and copper ions adsorption.

The modified carbon SPEs were comparatively studied for their electrocatalytic activity towards nitrate reduction in the presence of the single metals (either Ag or Cu) or both Ag and Cu. While Cu modified SPE exhibited a pronounced voltametric nitrate reduction wave and the presence of Ag alone did not show any electrocatalytic activity, the Ag-Cu-modified SPEs displayed well-pronounced electrocatalytic effect. Optimization of the Cu:Ag ratio in view of further improvement of the electrocatalytic performance is in progress.

Acknowledgments: Financial support of Bulgarian National Science Fund under project КП-06-M79/1 and Bulgarian Ministry of Education and Science under project D01-96/2025 of INFRAMAT are gratefully acknowledged.

[1] A. Nakova, M. Abrashev, V. Tsakova, *J. Solid State Electrochem.*, **2024**, 28, 1691-1703.

[2] Ch.Hyusein, V.Tsakova, *J. Chem. Techn. Metallurgy*, **2023**, 58, 1044-1050.

Stretchable and conductive PEDOT-thermoplastic elastomer films

L. Fiket¹, Y. Uda², J. Travas-Sejdic^{2,3}, Z. Katančić¹

¹University of Zagreb Faculty of Chemical Engineering and Technology, Zagreb, Croatia, ²School of Chemical Sciences, The University of Auckland, Auckland, New Zealand, ³The MacDiarmid Institute of Advanced Materials and Nanotechnology, Wellington, New Zealand
e-mail: katancic@fkit.unizg.hr

Conductive polymers have emerged as promising materials for application in different fields of flexible electronics, and among them, poly(3,4-ethylenedioxythiophene) (PEDOT) is widely recognized for its tunable conductivity, ease of processing, and stability in diverse environments [1]. However, the inherent brittleness of PEDOT limits its use in applications requiring high mechanical flexibility and durability [2]. Most commonly, PEDOT is doped with poly(styrene sulfonate) (PSS) to form PEDOT:PSS, a material widely used in flexible bioelectronics [3]. However, PEDOT:PSS has notable drawbacks, including its hygroscopic nature, which can lead to water absorption in devices and degradation of electrodes over time, particularly in moisture-rich environments, negatively affecting the long-term stability of the devices [4]. One promising approach to replacing PSS is the integration of PEDOT with elastomeric materials, such as sulfonated polystyrene-block-poly(ethylene-ran-butylene)-block-polystyrene (S-SEBS) [5]. The introduction of S-SEBS, a highly elastic thermoplastic elastomer, provides mechanical stretchability. In this work, a PEDOT-based composite material was developed that combines the stretchability and water stability of PEDOT:S-SEBS with self-healing functionality. This is achieved by grafting poly(acrylate-urethane) (PAU) onto the PEDOT derivative (PEDOT-*g*-PAU:S-SEBS), where PAU provides dynamic non-covalent cross-links via hydrogen bonding [6]. These cross-links break under mechanical stress to dissipate energy and reform when the stress is released, restoring the material's mechanical properties and electrical conductivity. A two-step synthesis strategy was designed: the first step involved preparing a PEDOT-based macroinitiator containing reactive bromine end groups, suitable for subsequent functionalization. In the second step, the macroinitiator PEDOT-Br:S-SEBS was subjected to atom transfer radical polymerization (ATRP) with the acrylate-urethane (AU) monomer, enabling the controlled grafting of functional side chains (Figure 1). This synthetic strategy combines the electrical conductivity of PEDOT, the mechanical elasticity of S-SEBS, and the dynamic hydrogen-bonding-driven self-healing functionality provided by the grafted PAU chains into a single stretchable and durable composite material.

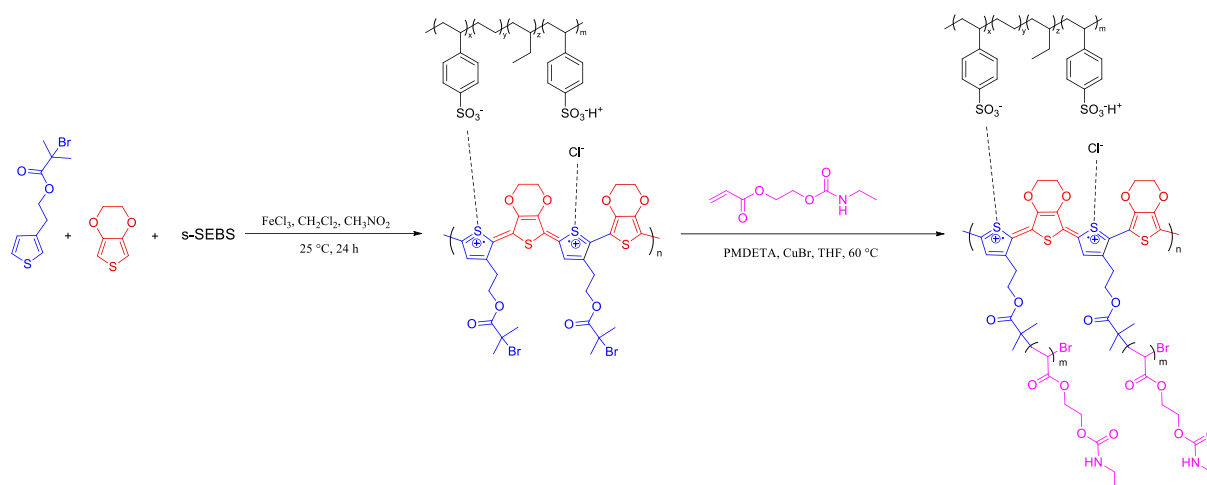

Figure 1. Synthesis of macroinitiator PEDOT-Br:S-SEBS and PEDOT-*g*-PAU:S-SEBS

Mechanical testing and self-healing experiments confirmed the robustness and durability of these composites. The self-healed films exhibited significantly higher tensile strength and lower strain at break than pristine films (Table 1).

Table 1. Mechanical properties of PEDOT-Br:S-SEBs and PEDOT-*g*-PAU:S-SEBS samples

Samples	Young's modulus (MPa)	Strain at break (%)	Tensile stress at break (MPa)
PEDOT-Br:S-SEBS	41.8 ± 2.3	204.3 ± 46.3	7.0 ± 3.0
PEDOT- <i>g</i> -PAU:S-SEBS	24.0 ± 10.6	346.2 ± 72.7	11.9 ± 0.8
Self-healed PEDOT- <i>g</i> -PAU:S-SEBS	33.0 ± 1.2	198.5 ± 33.9	19.6 ± 1.6

Failure did not occur at the healed cut, indicating that the repaired joint is not the weakest point of the sample. The electrical conductivity of PEDOT-*g*-PAU:S-SEBS films was evaluated before and after self-healing; the initial conductivity of $2.88 \pm 0.27 \text{ S cm}^{-1}$ decreased to $1.95 \pm 0.19 \text{ S cm}^{-1}$. Despite the decrease in conductivity, the films maintained sufficient electrical performance and stability for practical applications, as tested by measuring relative resistance change during ten stretch–release cycles at 50% and 75% strain. No progressive drift or signal deterioration was detected, showing that the composite maintains both mechanical integrity and electrical functionality under cyclic loading. The sensing functionality of the fabricated films was demonstrated by recording electromyographic (EMG) signals at two locations (forearm and biceps). The signal-to-noise ratio remained comparable between pristine and self-healed films, further confirming that the healing process does not impair sensing function (Figure 2).

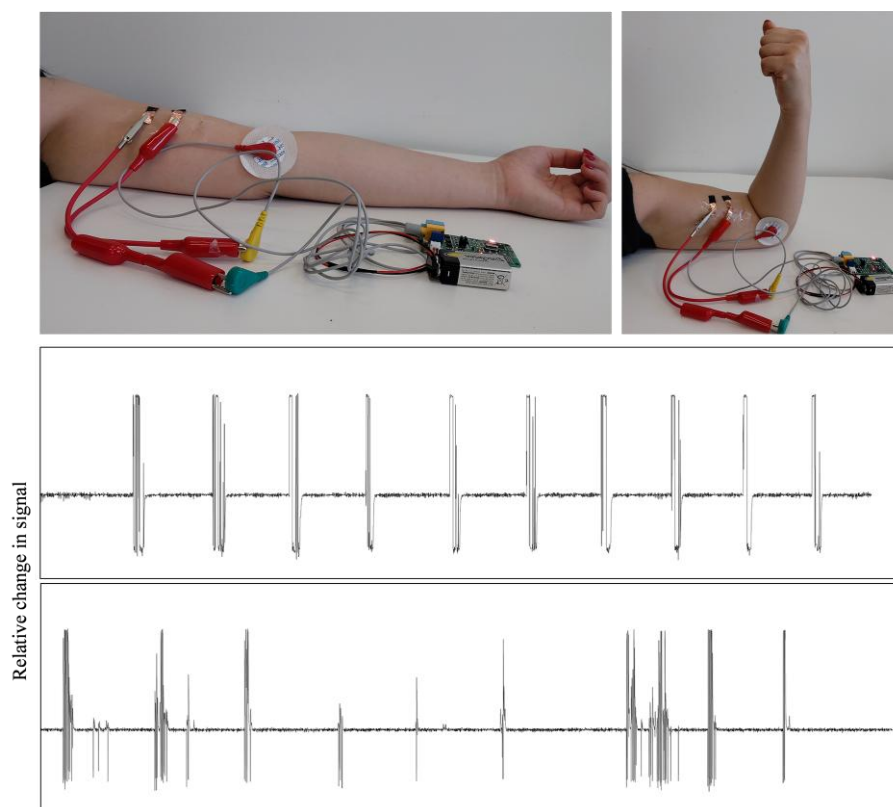

Figure 2. PEDOT-*g*-PAU:S-SEBS and self-healed PEDOT-*g*-PAU:S-SEBS graft copolymer films were tested as electrodes for EMG measurements (top), EMG response using the PEDOT-*g*-PAU:S-SEBS (middle) and EMG response using the self-healed PEDOT-*g*-PAU:S-SEBS (bottom).

These findings demonstrate that integrating molecularly engineered side chains is an effective strategy for developing conductive, stretchable and self-healing materials for wearable electronics and soft biointerfaces.

Acknowledgments: This work has been supported and funded by University of Auckland and Croatian Science Foundation under the projects UIP-2019-04-8304 and MOBOK 2023-5991

- [1] J. Ouyang, *SmartMat*, **2021**, 2, 263-285.
- [2] Y. Yang, G. Zhao, X. Cheng, H. Deng, Q. Fu, *ACS Appl. Mater. Interfaces*, **2021**, 13, 14599-14611.
- [3] Z. Wang, R. Liu, *Mater. Today Electron*, **2023**, 4, 100036.
- [4] Y. Jiang, Y. Zhou, *Nat. Energy*, **2022**, 7, 1310-311.
- [5] Y. Uda, P. Zhang, J. Travas-Sejdic, *Polym. Chem.*, **2024**, 15, 2342-2353.
- [6] L. Fiket, M. Božičević, L. Brkić, P. Žagar, A. Horvat, Z. Katančić, *Polymers*, **2022**, 14, 2340.

ABSTRACT OF POSTER PRESENTATION

Tailoring the capacitive properties of MXene via functionalization with long-chain phosphonic acids

K. Stjepanović², A. Brzić¹, G. Ljubek², A. Kapitanović¹, N. Zdošek³, M. Kraljić Roković¹

¹ University of Zagreb, Faculty of chemical engineering and technology, Marulićev trg 19, Zagreb, Croatia

² University of Zagreb, Faculty of mining, geology and petroleum engineering, Pierottijeva 6, Zagreb, Croatia

³ Ruđer Bošković Institute, Bijenička cesta 54, Zagreb, Croatia

e-mail: gabrijela.ljubek@rgn.unizg.hr

MXene is new class of materials composed of layers of transition metal atoms and carbon or nitrogen atoms, forming unique 2D structure. MXene materials attract tremendous attention due to their high theoretical specific surface area, superior electrical conductivity and favorable mechanical properties, which make them promising candidates for applications in electrochemical power sources. However, several limitations still hinder their wider application, including agglomeration of 2D sheets, instability and oxidation. Therefore, additional modifications of MXene are important for their practical implementation. One of the most promising approaches for tailoring MXene properties is surface functionalization. The tunable surface chemistry of the MXene enables modification with various functional groups such as phosphoric, carboxylic, silanol and amino groups [1].

In this work, MXene was successfully modified with long chain phosphonic acids that was proved by structural analysis with Fourier-transform infrared spectroscopy, Raman spectroscopy and contact angle measurements. Electrochemical properties of the prepared materials were tested by cyclic voltammetry and electrochemical impedance spectroscopy in various electrolytes containing Na, K, Ca or Zn- salts. The influence of cation size and hydration shell on the capacitive properties of modified MXene was determined. Stability of the prepared layers over the time was tested by electrochemical methods.

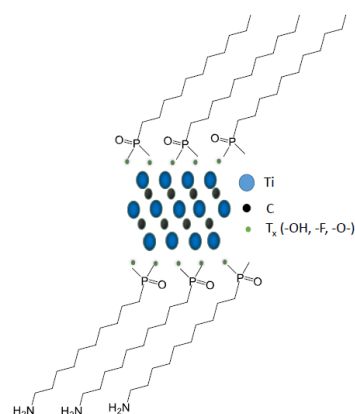

Fig. 1. The structure of the functionalized MXene.

Acknowledgments: This work has been supported by the Next Generation NPOO project (MXeneFun-Recovery and Resilience Mechanism) funded by the European

International Workshop
on Electrochemistry of Electroactive Materials
May 24–29, 2026, Bellamonte, Italy

WEEM-2026

Union.

[1] S. Jung, et al, *EcoMat*, **2023**, 5, e12395. DOI: 10.1002/eom2.12395

Electrochemical chemotransistors with internal integrity control: design, optimization and applications as virtual sensor arrays for analysis of fish freshness

Yulia Efremenko¹, Eya Boughanmi^{1,2}, Vladimir M. Mirsky¹

¹Brandenburg University of Technologies Cottbus – Senftenberg, 01968 Senftenberg, Germany

²University of Tunis El Manar, Tunis, Tunisia

e-mail: mirsky@b-tu.de

Electrochemical chemotransistor is a new type of transducer that allows one to create chemical sensors with electrically controlled affinity. This feature enables the construction of virtual sensor arrays consisting of a physically single sensing element. This device was designed as a miniature glass chip with five gold electrodes: four (measurement electrodes) are used for simultaneous two- and four-point resistance measurements of the chemosensitive conducting polymer while the fifth one (controlling electrode) defines the redox-state of the polymer. Simultaneous two- and four-point resistance measurements provide information on the contact resistance, which is used as an internal control of the sensor integrity. Electrical connection between the fifth electrode and the chemosensitive polymer is made through a thoroughly optimized highly stable electrolyte based on room-temperature ionic liquid containing ions of chloride. The electrode is coated with silver/silver chloride layer to create a stable potential jump at the polymer/ionic liquid interface. The ionic liquid was optimized to minimize its evaporation and water absorption in a typical air environment.

The new transducer has a wide range of applications. In particular, the realization of a sensor for analyzing fish freshness will be discussed. Measurements using a single model analyte (trimethylamine) demonstrated exponential kinetics. But the response kinetics to the fish headspace were more complex and non-exponential, with non-monotonous dependencies of its characteristics on the fish storage time. Therefore, data clusterization was applied. After measurements of response kinetics at three different potentials of the controlling electrode, nine descriptors were extracted (three for each curve). The storage time was determined by minimizing the Euclidean distance between the nine descriptors obtained during the analysis and the corresponding descriptors for different storage times obtained during the sensor calibration; the calculation was performed in the nine-dimensional space formed by these descriptors. The developed approach can be extended to other complex analytes.

Acknowledgments: The work was supported by European Commission (Y.E., V.M.M., Project FishEUTrust) and DAAD (E.B.).

Combustion- and Precipitation-Derived Zn–Co Oxide Spinel as Electrochemically Active Coatings for Energy Storage and Photoelectrochemical Applications

Kristijonas Kacevičius¹, Fausta Bukučinskaitė¹, Maria-Anthoniette Oghenetejiro Onoriode-Afunezie¹, Agnė Šulčiūtė¹

¹*Kaunas University of Technology, Kaunas, Lithuania,
e-mail: maria.onoriode@ktu.edu*

INTRODUCTION

Spinel-type mixed metal oxides have attracted significant attention as electrochemically active materials due to their structural stability, high electrical conductivity, and multiple oxidation states. Among these materials, ZnCo₂O₄ has emerged as a promising candidate for electrochemical energy storage, electrocatalysis, and photoelectrochemical (PEC) applications because the coexistence of cobalt oxidation states enables efficient redox reactions and rapid charge transfer [1].

Recent studies have demonstrated that nanostructured ZnCo₂O₄ materials can exhibit high capacitance and good cycling stability when used as electrode materials in supercapacitors. For example, nanowire-structured ZnCo₂O₄ electrodes provide a large surface area and short ion diffusion pathways, resulting in improved electrochemical performance and long-term cycling stability [2].

Furthermore, hierarchical or composite ZnCo₂O₄ systems have been shown to enhance electrochemical activity through increased surface area and improved conductivity. For instance, hybrid ZnCo₂O₄-based composites can achieve high specific capacities and stable performance due to synergistic interactions between the spinel oxide and secondary components [3].

Despite these advances, the influence of synthesis method on the structural and electrochemical properties of Zn–Co oxide coatings remain insufficiently explored, particularly for scalable thin-film deposition techniques. Understanding how synthesis routes affect morphology, crystallinity, and electrochemical performance is therefore important for the development of efficient electrode materials.

This study compares two distinct synthesis kinetics—slow precipitation and rapid combustion—to determine how the resulting material density influences the optimal architecture of spray-deposited coatings for energy storage.

Materials and Methods

In this work, Zn–Co oxide catalysts were synthesized using two wet-chemical approaches derived from two independent research studies. The first synthesis route employed combustion synthesis, in which zinc and cobalt precursors were thermally decomposed to form ZnCo₂O₄ spinel powders. The precursor mixture was initially calcined at moderate

temperature to remove organic components and subsequently annealed at approximately 600 °C to promote the formation of the spinel phase.

The second synthesis route involved precipitation from aqueous solution, where zinc and cobalt salts were co-precipitated using an alkaline agent to obtain mixed hydroxide precursors. After filtration and drying, the resulting precipitates were thermally treated at higher temperature (around 660 °C) to generate crystalline Zn–Co oxide materials.

The synthesized powders were deposited onto conductive glass substrates via spray coating, enabling the preparation of thin-film electrodes with controlled thickness. Coating thickness varied by adjusting the number of deposited layers, typically ranging from one to twenty layers.

Results and Discussion

Structural and compositional characterization confirmed spinel phase formation for both synthesis routes, with noticeable differences in crystallinity and surface morphology. While both synthesis routes successfully produced the ZnCo_2O_4 spinel phase, the electrochemical performance revealed a striking divergence in layer optimization. Precipitation-derived coatings reached peak specific capacitance and photoelectrochemical efficiency (IPCE) at only 3 layers, whereas combustion-derived coatings required 16 layers to achieve maximum performance. Electrochemical testing revealed that coating architecture strongly influences performance, with optimized layer numbers leading to enhanced capacitive behavior. These trends are consistent with recent studies demonstrating the importance of ZnCo_2O_4 nanostructure and interface engineering for photoelectrochemical applications [4], [5], [6].

Among the investigated samples, combustion-derived ZnCo_2O_4 coatings with intermediate thickness (approximately sixteen layers) showed the most favorable electrochemical performance. These electrodes displayed stable cyclic voltammetry profiles and enhanced charge-storage behavior. The 3-layer precipitation-derived samples demonstrated that high-temperature annealing (660 °C) can produce highly active surface sites that do not require thick bulk layers to facilitate charge transfer.

The observed performance trends are consistent with previous studies reporting that nanostructured ZnCo_2O_4 electrodes exhibit high electrochemical activity due to their redox-active cobalt centers and large surface area [2].

Overall, this study demonstrates that synthesis route and coating design play a critical role in determining the electrochemical and photoelectrochemical performance of Zn–Co oxide spinels, providing practical guidelines for their application in energy storage and photoelectrochemical systems. The combination of scalable synthesis methods and spray deposition also provides a flexible strategy for tailoring electrode architecture. Our findings conclude that the synthesis route dictates the coating design: the precipitation method is ideal for ultra-thin, high-efficiency coatings (3 layers), while the combustion method is better suited for thicker, more robust active layers (16 layers).

References:

- [1] T. W. Kim, M. A. Woo, M. Regis, and K.-S. Choi, 'Electrochemical Synthesis of Spinel Type ZnCo₂O₄ Electrodes for Use as Oxygen Evolution Reaction Catalysts', *J. Phys. Chem. Lett.*, vol. 5, no. 13, pp. 2370–2374, Jul. **2014**, doi: 10.1021/jz501077u.
- [2] X. Sun, D. Zhang, A. Umar, and X. Wu, 'Ternary ZnCo₂O₄ Nanowire Electrode Materials for High-Capacitance and Flexible Electrochemical Capacitors', *ACS Appl. Energy Mater.*, vol. 6, no. 18, pp. 9594–9601, Sep. **2023**, doi: 10.1021/acsaem.3c01640.
- [3] X. Liao, H. Yang, X. Hou, C. Yi, Y. Yang, G. Wang, S. Wang, Y. Liu, C. Chen, D. Yu and X. Zhou, 'Synthesis and performances of a ZnCo₂O₄@MnMoO₄ composite for a hybrid supercapacitor', *Dalton Trans.*, vol. 53, no. 35, pp. 14767–14778, Sep. **2024**, doi: 10.1039/D4DT01896F.
- [4] C.-Y. Lin, A. K. Sharma, T.-M. Cheng, C.-C. Kaun, C.-W. Chang, and Y.-H. Su, 'Spin-to-charge conversion of chloroplast-functionalized ZnCo₂O₄ electrode in photoelectrochemical water splitting', *Sustainable Materials and Technologies*, vol. 45, p. e01516, Oct. **2025**, doi: 10.1016/j.susmat.2025.e01516.
- [5] S. Majumder, A. A. Yadav, Y. M. Hunge, A. A. Jeffery, N. Thomas, R. A. Alshgari, E. Chicardi, M. Mushab, & K. H. Kim, 'Exploring FeVO₄/ZnCo₂O₄ *n-p* heterojunctions for superior photoelectrochemical performance', *Journal of Alloys and Compounds*, vol. 1010, p. 177281, Jan. **2025**, doi: 10.1016/j.jallcom.2024.177281.
- [6] L. Yu, W. Gong, X. Zhao, H. Zhu, and Y. Zhang, 'Layered BiVO₄ photoanodes modified by microwave hydrothermal ZnCo₂O₄ to alleviate sluggish water oxidation kinetics for water splitting', *International Journal of Hydrogen Energy*, vol. 127, pp. 793–800, May **2025**, doi: 10.1016/j.ijhydene.2025.04.183.

Functionalized MXene Chemiresistors as Sensors for Humidity and NO in Breath Diagnostics

E. Pargoletti^{1,2}, B. Davis², Y. Gogotsi²

¹*Dipartimento di Chimica, Università degli Studi di Milano, Milan, Italy*

²*A.J. Drexel Nanomaterials Institute, Materials Science & Engineering, Drexel University, Philadelphia (PA), US*

e-mail: eleonora.pargoletti@unimi.it

1. Introduction

The development of reliable and low-cost gas sensors for breath analysis is gaining increasing attention as a non-invasive diagnostic tool for respiratory diseases [1-3]. Among gaseous biomarkers, nitric oxide (NO) is particularly relevant, as its concentration in exhaled breath correlates with airway inflammation [4,5].

Chemiresistive sensors based on 2D materials, such as MXenes, represent a promising alternative to conventional semiconductor metal oxides due to their high electrical conductivity, large surface area, and room-temperature operation [6,7]. However, their intrinsic hydrophilicity and limited selectivity remain critical challenges. Surface functionalization with organic molecules, such as 3-mercaptopropyltrimethoxysilane (MPTMS), offers a viable strategy to modulate both surface chemistry and electronic properties.

In this work, $Ti_3C_2T_x$ and Nb_2CT_x MXenes, both pristine and MPTMS-functionalized (20%), were investigated as chemiresistive sensors for NO detection under variable relative humidity (RH), with a focus on room-temperature operation.

2. Physicochemical characterization

The successful synthesis and functionalization of MXenes were confirmed through XRPD, FT-IR, and TEM analyses.

XRPD patterns show the characteristic (002) reflection of layered MXenes (Figures 1a,b). Upon functionalization, a shift toward lower diffraction angles is observed, indicating an increase in interlayer spacing due to the insertion of MPTMS molecules. This confirms effective intercalation and surface modification. FTIR spectra further support the functionalization process (Figures 1c,d). In both $Ti_3C_2T_x$ and Nb_2CT_x , new vibrational bands appear in the $1000-1150\text{ cm}^{-1}$ region, assigned to Si–O–Si and Si–O–M (M = Ti, Nb) bonds, along with C–H stretching modes around 2900 cm^{-1} . The decrease in –OH-related bands suggests partial replacement or shielding of surface terminations. TEM analysis reveals the typical layered morphology of MXenes (insets of Figure 1). $Ti_3C_2T_x$ exhibits large, flexible flakes (micrometer scale), while Nb_2CT_x consists of smaller, more compact flakes (hundreds of nanometers). Functionalization does not significantly alter morphology but promotes slight aggregation and structural modification at the nanoscale.

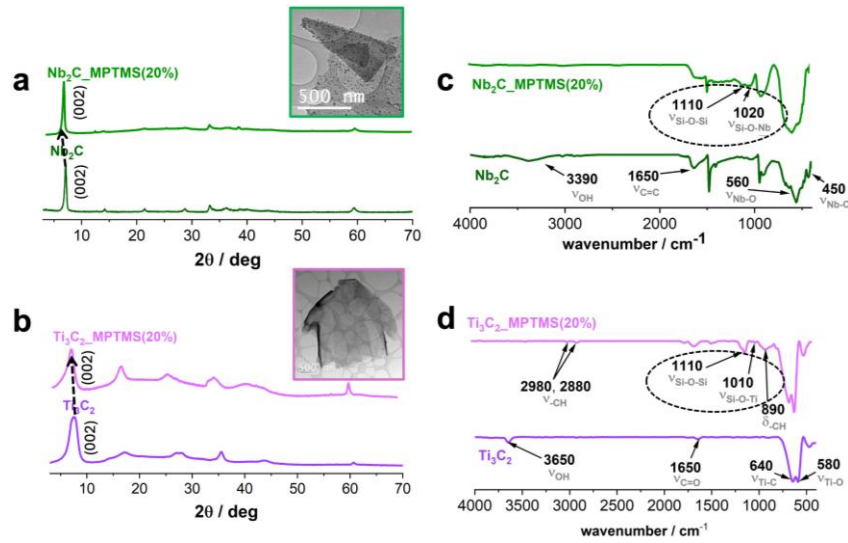

Figure 1. (a,b) Comparison of XRPD patterns of pristine and MPTMS-modified MXenes. Insets: TEM images of modified Nb₂CT_x (above) and Ti₃C₂T_x (below). (c,d) Comparison of FTIR spectra.

3. NO sensing performance

Gas sensing tests were performed at room temperature under different relative humidity conditions (10-85% RH) using 5 ppm NO as the reference concentration.

The sensor response was defined as:

$$S = \frac{R_{\text{air}}}{R_{\text{NO}}} - 1$$

Distinct sensing behaviors were observed depending on the MXene composition and functionalization.

In particular, pristine and modified-Ti₃C₂T_x exhibit a sensing response consistent with a p-type-like semiconducting behavior. In this case, exposure to NO (a reducing gas [8]) leads to a decrease in hole concentration, resulting in an increase in resistance. This trend is consistent with established models for p-type semiconductors. Conversely, both pristine and functionalized Nb₂CT_x exhibit positive responses (increase in conductance) upon NO exposure, indicating n-type behavior. According to the literature on n-type semiconductors such as WO₃, reducing gases like NO donate electrons to the material, decreasing resistance. Functionalization with MPTMS significantly enhances the response amplitude, likely due to both reduced hydrophilicity (limiting interference from water vapor), and specific interactions between thiol groups (–SH) and NO molecules. All sensors demonstrate measurable responses down to 5 ppm NO at room temperature, with preliminary results indicating a limit of detection approaching 0.1 ppm, which is highly relevant for breath analysis applications.

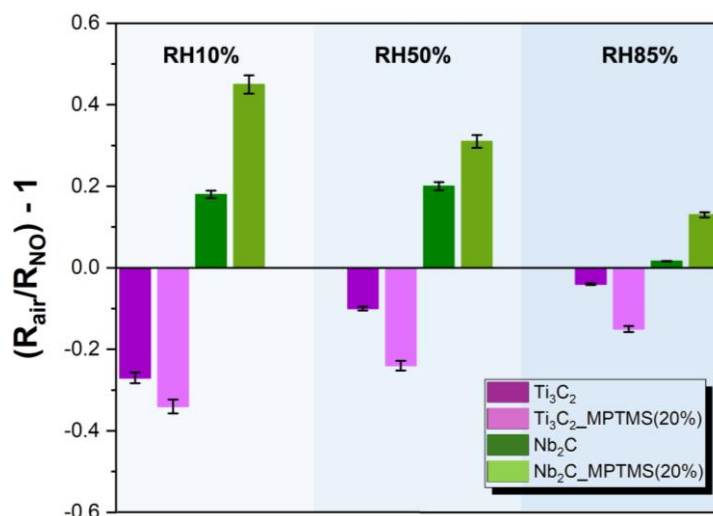

Figure 2. Comparison of sensors signals obtained with pristine and modified MXenes at different RH%, toward 5 ppm of NO (operating temperature = 25 °C; average values on three replicates).

The ability to operate at RT represents a significant advantage compared to conventional metal oxide sensors, which typically require elevated temperatures (200–400 °C) to achieve comparable performance. Lastly, concerning the humidity interference, it strongly influences sensor response. However, functionalized samples exhibit reduced humidity interference, particularly for Nb₂C_{T_x}, confirming the role of MPTMS in modulating surface hydrophilicity.

4. Conclusions

This study demonstrates that surface functionalization of MXenes with MPTMS is an effective strategy to tune both sensing performance and electronic behavior. Specifically, Ti₃C₂T_x exhibited a p-type behavior toward NO sensing, whereas Nb₂C_{T_x} showed an n-type behavior, in both cases with enhanced sensitivity after modification. Moreover, MPTMS reduced humidity interference and improved NO interaction, likely via S–NO interactions, and detection at sub-ppm levels was achievable at room temperature, highlighting strong potential for breath diagnostics.

These findings provide new insights into the design of MXene-based chemiresistors and open the way for portable, low-power gas sensing devices.

- [1] Tricoli, Nasiri, et al., *Adv. Funct. Mater.*, **2017**, 27, 1605271.
- [2] Pargoletti*, Vertova, et al., *ACS Sens.*, **2025**, 10, 407–416.
- [3] Tessore, Pargoletti*, et al., *ACS Appl. Mater. Interfaces*, **2024**, 16, 41086–41098.
- [4] Kobayashi, Hanagama, et al., *Respiratory investigation*, **2021**, 59, 364–366.
- [5] Maniscalco, M., Mormile, et al., *Cells*, **2023**, 12, 2518.
- [6] Naguib, Kurtoglu, Presser, et al., *Advanced Materials*, **2011**, 23, 4248–4253.
- [7] Alhabeab, Maleski, Anasori, et al., *Chemistry of Materials*, **2017**, 29, 7633–7644.
- [8] Mineo, Moulae, Neri, et al., *Chemosensors*, **2022**, 10, 492.

A new method for deposition of Pd-Au bimetal nanocatalysts on carbon substrates

R.Peneva¹, St. Atanasova-Vladimirova¹, D. Karashanova², S. Ivanov¹, V. Tsakova¹

¹ *Institute of Physical Chemistry, Bulgarian Academy of Sciences, Sofia, Bulgaria,*

² *Institute of Optical Materials and Technologies, Bulgarian Academy of Sciences, Sofia, Bulgaria*
e-mail:rpeneva@ipc.bas.bg

Recently Ag-Pd bimetal nanoheterostructures were obtained on carbon electrodes through an innovative method [1]. The latter consists of cathodic pre-treatment of the carbon substrates in supporting electrolyte, in the absence of depositing metal ions, followed by immediate dipping in the metal plating solution under open circuit conditions. The deposition of the two metals was carried out sequentially from plating solutions of the individual metal ions. In this work Pd and Au are co-deposited on cathodically pre-treated electrodes in a single step by using mixed aqueous solutions of 2 mM/l PdCl₂ and 2 mM/l HAuCl₄ with different ratios of both electrolytes: 1:1, 3:1, 10:1. Screen printed electrodes (SPEs) consisting of mesoporous carbon, carbon nanofibers (CNF) and carbon nanotubes (CNT) were used as working electrodes.

The characteristics of the deposited metal nanoparticles (NPs) were studied by cyclic voltammetry, scanning electron microscopy, energy dispersive spectroscopy (EDS) and high-resolution transmission electron microscopy (HRTEM).

EDS analysis, performed on individual metal NPs, gave evidence for the presence of both Au and Pd in all particles. The average size of the deposited NPs was found to vary between 16 and 22 nm depending on the type of the carbon substrate whereas the solution composition did not significantly affect the NPs size. The total content of the metals, evaluated by EDS analysis at low magnifications, revealed differences in the Pd;Au ratio depending both on the type of SPE and the composition of the plating solution. Lower concentration of the palladium ions in the mixed solution resulted in lower Pd:Au ratio in the metal deposit. Between the different types of SPEs CNF exhibited the highest Pd:Au content in all three plating solutions. HRTEM revealed the existence of composite metallic NPs consisting of individual Pd- and Au-, and alloy Pd-Au-phases.

The electrocatalytic activity for ethanol oxidation was tested on the bi-metal modified SPEs and compared to the performance of Pd-only-modified electrodes. The ethanol oxidation peaks recorded on Pd-Au-modified CNF and CNT SPEs (obtained from a mixed 10:1 solution) significantly exceeded the corresponding Pd-modified SPEs. The proposed simple deposition method provides new opportunities

for the development of nanocatalysts involved in electrochemical reactions.

[1] A. Nakova, Ch. Hyusein, I. Zahariev, St. Atanasova-Vladimirova, B. Ranguelov, V. Tsakova, *Electrochim. Acta*, 2025, 524, 146008.

Acknowledgment: Financial support of Bulgarian Ministry of Education and Science under project D01-96/2025 of INFRAMAT is gratefully acknowledged.

ABSTRACT OF POSTER PRESENTATION

**Electroless deposition of thin metal films on various types of glass
using SnO₂ buffer coatings**

S. Petrova, Iv. Zahariev, D. Iazarova, G. Avdeev, M. Petrova

Department of Electrochemistry and Corrosion, Institute of Physical Chemistry, Bulgarian Academy of Sciences, "Acad. G. Bonchev" Str., Blok 11, 1113 Sofia, Bulgaria,

e-mail: spetrova@ipc.bas.bg

Glass is a widely used material in both everyday applications and electronics, which creates a need for effective metalization methods. Traditional physical techniques, such as vacuum evaporation and cathode sputtering, require expensive equipment and increase the cost of the final product. Chemical metallization is an effective alternative, enabling the deposition of thin, high-quality metal films with a mirror-like surface and high reflectivity. However, a major challenge associated with this approach remains the poor adhesion of the metal layers to glass substrates.

In the present study, thin tin dioxide (SnO₂) layers were deposited onto glass substrates by spray pyrolysis method under various geometric deposition conditions. This method is widely used for the fabrication of thin SnO₂ films. During the deposition process, nanoparticles are formed, which build up a thin polycrystalline film on the substrate. The thickness and structure of the film depend on the solution concentration, temperature, and spray rate. Different substrate mounting configurations and precursor solution spraying modes were investigated. The experiments were carried out using samples of standard microscope glass slides (Na₂O·CaO·6SiO₂).

After deposition of the thin SnO₂ layer by spray pyrolysis under the described conditions, the samples were subjected to pretreatment, including:

- activation in a colloidal Pd/Sn activator for 5 min at room temperature;
- acceleration in 1 M NaOH for 5 min at room temperature.

Electroless nickel–phosphorus and copper coatings were subsequently deposited onto the prepared surfaces and characterized in terms of thickness, roughness, contact angle, and adhesion to the substrate.

The results show that the morphology of the SnO₂ layer, controlled by the deposition conditions, is a key factor influencing the functional properties of the metal coatings. This

highlights the potential for optimizing such structures for applications in sensor technology and electronic devices.

The results also demonstrate that the investigated coatings exhibit characteristics comparable to those of metal films obtained by conventional physical methods, while offering higher technological and economic efficiency.

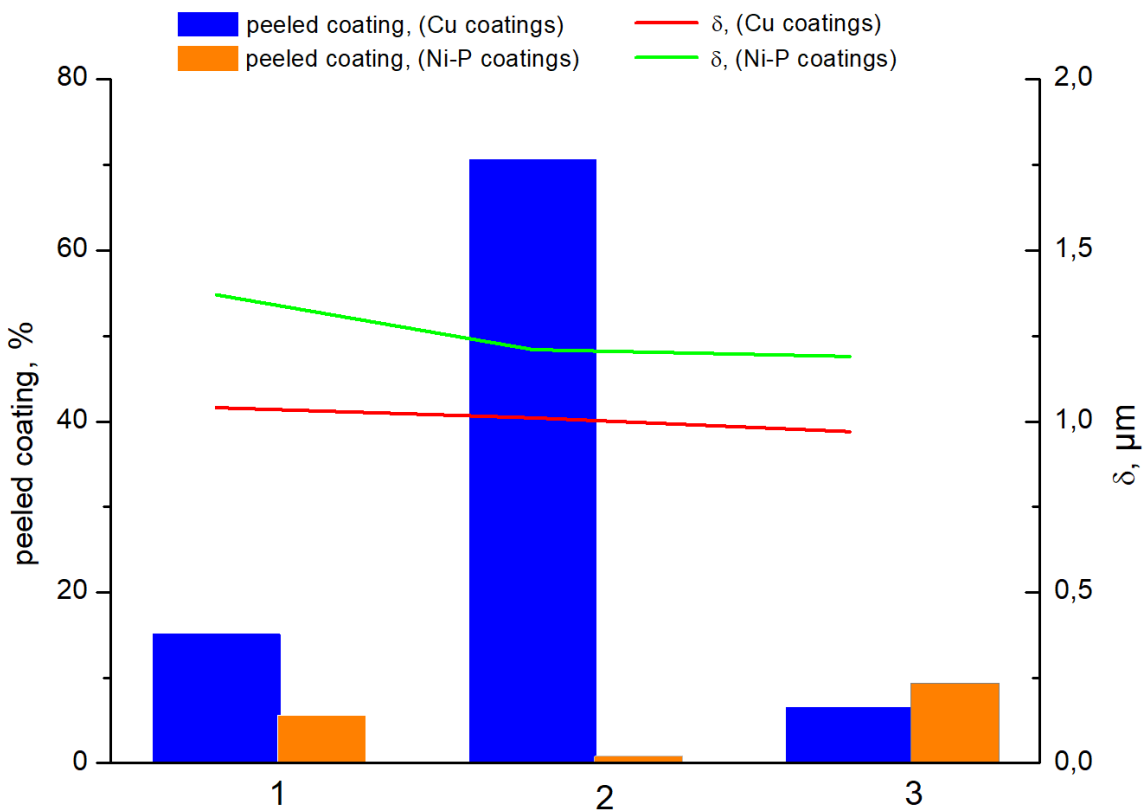

Fig. 1. Comparison of the percentage of coating delamination and the thickness δ (μm) for Cu and Ni–P coatings under different SnO_2 deposition conditions:

1. SnO_2 deposited at an angle, with a 30-minute interval between successive applications;
2. SnO_2 deposited at an angle immediately, without any pause between applications;
3. SnO_2 deposited horizontally immediately, without any pause between applications.

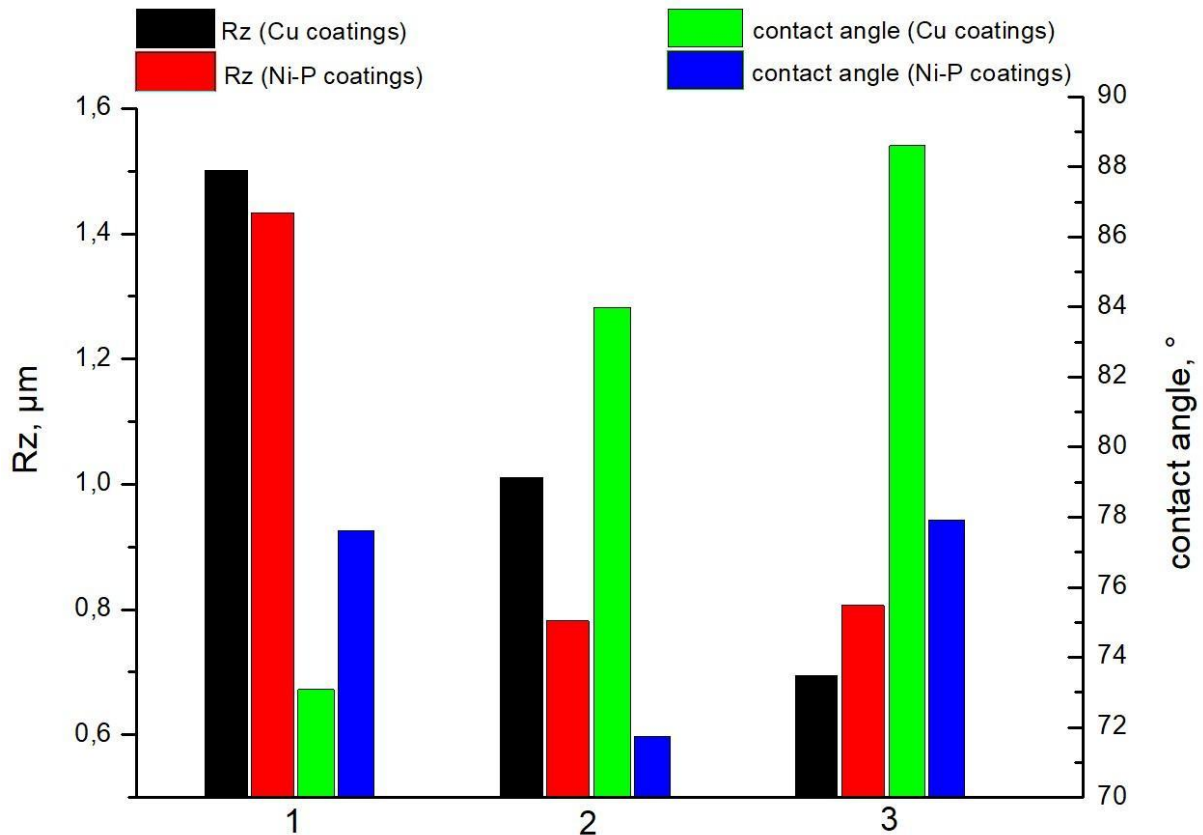

Fig. 2. Effect of surface roughness R_z on the contact angle under different SnO_2 deposition conditions:

1. SnO_2 deposited at an angle, with a 30-minute interval between successive depositions;
2. SnO_2 deposited at an angle consecutively, without any pause between depositions;
3. SnO_2 deposited horizontally consecutively, without any pause between depositions.

The results demonstrate that the deposition geometry of SnO_2 plays a crucial role in determining the structure and properties of the subsequently deposited metal layers. Deposition at an inclination of 45° leads to the formation of more homogeneous and uniform coatings with improved adhesion, whereas horizontal deposition promotes aerosol droplets accumulation and the formation of localized defects.

Acknowledgments: This research has been carried out within the Project КП-06-H97/6 “Development and Investigation of Innovative Methods for Obtaining Functional Composite Materials of the Dielectric/Metal Type”, funded by the National Science Found (Bulgaria).

SOOT-derived nanocomposites: a sustainable platform for advanced electroanalysis

V. Pifferi¹, W. Aidli¹, G. Cappelletti¹, M. Longhi¹, C. Ingrosso², F. Migliorini³,
I. Palchetti⁴, S. Laschi⁴, P. Sfragano⁴, L. Falciola¹

¹Università degli Studi di Milano, Dipartimento di Chimica, Milano, Italy

²CNR-IPCF, Via Orabona 4, Bari, Italy; ³CNR-ICMATE, Via Orabona 4, Milano, Italy

⁴Università degli Studi e UdR INSTM di Firenze, Via della Lastruccia 3, 50019 Sesto Fiorentino, Italy
e-mail: valentina.pifferi@unimi.it

Over the past three decades, carbon-based nanomaterials have revolutionized material science, emerging as cornerstone electroactive components for high-performance electrochemical sensors. Among these, carbon nanoparticles (CNPs) have gained significant traction due to their unique physicochemical properties. Unlike structurally defined counterparts such as graphene or carbon nanotubes, CNPs offer a cost-effective and scalable alternative without compromising performance. Their ease of functionalization and inherent biocompatibility are pivotal for next generation sensing platforms. However, traditional synthesis methods are often energy-intensive or rely on hazardous precursors, necessitating more sustainable production routes.

This study explores a promising circular approach by upcycling carbon SOOT as a sustainable source for CNPs. Specifically, soot particles produced via ethylene combustion were treated with an acidic pretreatment to introduce surface functional groups, facilitating the subsequent deposition of AuNPs. Two distinct synthesis routes for AuNP integration were compared: citrate-assisted and spontaneous reduction. The resulting hybrids were evaluated using two different supports: carbon paste electrodes and screen-printed electrodes. A comparative analysis was conducted to assess the impact of the synthesis route on structural morphology and electron transfer kinetics. The practical analytical performance was validated through the sensing of H₂O₂, a critical biological biomarker, or diclofenac, an emerging environmental contaminant.

Acknowledgements: we acknowledge financial support under the National Recovery and Resilience Plan (NRRP), Mission 4, Component 2, Investment 1.1, Call for tender No. 104 published on 2.2.2022 by the Italian Ministry of University and Research (MUR), funded by the European Union – NextGenerationEU– Project Title: UPcycling SOOT for sustainable nanocomposites-based wearable sensors (UP - SOOT) – CUP G53D23003000006 - Grant Assignment Decree No. 958 adopted on 30/06/2023 by MUR.

[1] A.K. Geim, K.S. Novoselov, *Nature Materials*, **2007**, 6(3),183-191.

[2] R. Niessner, *Angewandte Chemie*, **2014**, 53(46), 12366-12379.

Preliminary assessment of Li-ion portable batteries of general use in the EU¹

Quintero Pulido, D.F¹, Hildebrand, S¹., Hegedusova, L¹., Bruchhausen, M.¹

European Commission, Joint Research Centre (JRC), Directorate C - Energy, Mobility and Climate-Battery and Hydrogen Technologies, Westerduinweg 3, NL-1755 LE, Petten, the Netherlands.

Correspondence: diego.quintero-pulido@ec.europa.eu

This is the first assessment of rechargeable portable Li-ion batteries with internal circuitry, specifically designed to be interchangeable with regular portable batteries of general use (PBGU) with the common designations AAA, AA, D, C, and 9V. The primary objective of this research was to investigate the characteristics of Li-ion PBGU that can seamlessly replace traditional primary batteries and NiMH batteries in a variety of applications, including household devices and portable electronics.

This study focused on the current technology trends and testing of Li-ion PBGU. It is explored various aspects, including their electrochemical performance, safety features, compatibility with existing devices and charging methods. The research also examined the potential benefits and drawbacks of using Li-ion PBGU as replacements for traditional batteries, including their impact on the environment, energy efficiency, and cost-effectiveness. Additionally, recommendations for future research and development are presented, highlighting areas that require further investigation and innovation to provide an analysis of the potential and impact of Li-ion PBGU in the EU market.

Reference:

¹QUINTERO PULIDO, D., HILDEBRAND, S., HEGEDUSOVA, L. and BRUCHHAUSEN, M., Preliminary assessment of Li-ion portable batteries of general use in the EU, Publications Office of the European Union, Luxembourg, 2025, <https://data.europa.eu/doi/10.2760/9355384>, JRC143662.

Characterization and Reproducibility Assessment of Commercial Screen-Printed Carbon Electrodes

A. Secundo, V. Pifferi, M. Shhata, L. Falciola

Università degli Studi di Milano, Dipartimento di Chimica, Milano, Italy
e-mail: anna.secundo@unimi.it

Screen-printed carbon electrodes (SPCEs) are pivotal in electroanalysis due to their low cost, portability, and tunable surface chemistry [1,2]. Despite their versatility in environmental and biomedical sensing [3,4], significant performance variability between manufacturers and batches can compromise measurement reliability [2,5]. Consequently, systematic characterization is essential to determine the interchangeability of these devices in practical applications.

This study systematically compares several commercially available SPCEs using cyclic voltammetry (CV) and electrochemical impedance spectroscopy (EIS). Using the ferri/ferrocyanide redox couple as a benchmark [3,4], we evaluated electron transfer kinetics, electroactive surface area, and signal stability. The assessment highlights critical discrepancies in reproducibility and batch-to-batch dispersion, even among electrodes with similar nominal specifications [1,5]. Morphological and compositional analyses were included to support the electrochemical findings.

The results provide practical benchmarking criteria for selecting SPCEs, helping researchers balance electrochemical performance with reproducibility requirements [5,6]. Furthermore, preliminary investigations into surface modifications, such as electropolymerization, were conducted to explore performance enhancements and surface-dependent selectivity.

- [1] R.D. Crapnell, C.E. Banks, *ChemElectroChem*, **2024**, 11.
- [2] R. Andreeva, A. Tsanev, G. Avdeev, D. Stoychev, *Metals*, **2025**, 15.
- [3] Z. Taleat, A. Khoshroo, M. Mazloum-Ardakani, *Microchimica Acta*, **2014**, 181, 865-891.
- [4] J. Barton, M.B.G. García, D.H. Santos, *Microchim Acta*, **2016**, 183, 503–517.
- [5] Z. Lihua, H. Hongliang, M. Zhanfang, *Biosensors and Bioelectronics*, **2018**, 101, 304-310.
- [6] S.R. Subramaniam, Z.Z. Abidin, M.A. Issa, N.H. Harun, M.Y. Pudza, *Water, Air, and Soil Pollution*, **2025**, 236(14).

Impact of the Experimental Conditions for the Electrogeneration of a Molecularly Imprinted Polymers (MIP) on the Performance of Perfluorooctane Sulphonic Acid (PFOS) Detection

M. D. P. Souza¹, A. M. Stortini¹, N. Karimian¹, S. Daniele¹, C. Zanardi^{1,2}

¹Department of Molecular Sciences and Nanosystems, Ca' Foscari University of Venice, Venezia, Italy

²Institute for Organic Synthesis and Photoreactivity, National Research Council, Bologna, Italy

e-mail: michael.souza@unive.it

Perfluorooctanesulfonic acid (PFOS) is a persistent organic pollutant belonging to the perfluoro- and polyfluoroalkyl (PFAS) derivatives, requiring sensitive and reliable monitoring in water sources [1,2]. Besides the use of chromatographic techniques, which allow for reaching very low limit of detection, the application of portable sensors guarantees a more widespread analysis of water samples. One of the sensing strategies normally used for the detection of PFOS is the use of molecularly imprinted polymers (MIPs), which enable the amperometric detection of this species despite its lack of electroactivity. Starting from previous studies involving poly(ortho-phenylenediamine) (oPD) based sensors [3], this work explores a redesign of the MIP fabrication process and of the transduction protocol to address common challenges related to baseline evolution and presence of false positive alerts.

This study investigates the mechanistic aspects of PFOS imprinting within electropolymerized oPD films, focusing on three critical parameters: the parameters used for the electropolymerization step, the condition chosen for the analysis, and the role of the redox mediator.

As to the polymer electrogeneration step, chronoamperometry (CA) is shown to offer a significant advantage over traditional cyclic voltammetry (CV), reducing polymer deposition time by over 90% while yielding a more compact, homogeneous and reproducible polymer film. The concentration of PFOS template plays a major role in the sensor performance: high concentrations (1.0 mM) normally used in this step promote template aggregation, resulting in poorly defined binding sites and reduced analytical response, whereas intermediate concentrations (0.3 mM) favor the formation of well-defined cavities, improving sensor sensitivities. The optimization of the deposition parameters, performed with a Design of Experiments (DoE) also considered the deposition time, which allows the modulation of the film thickness.

As to the sensing step, we strictly define the influence of charge of redox probe and of the pH of the solution on the signal transduction, starting from the parameters normally used for MIP-based sensors, i.e. the use of ferrocenecarboxylic acid at pH 8. The use of hexaammineruthenium as the redox probe and adjustment of the electrolyte to pH 5 allow to take advantages of the positively charged oPD in the interaction with PFOS and to achieve an effective separation between the probe reduction signal from the intrinsic redox activity of the oPD film, thereby improving baseline stability and measurement reliability. In any case the detection step is performed in measuring solution containing the redox probe after conditioning the MIP-based sensor in the measuring solution containing the sample.

The sensor obtained and used under optimized conditions operates via a signal-off mechanism driven by steric hindrance upon PFOS rebinding. The practical applicability of the platform is validated using real water samples, demonstrating excellent recovery rates and minimal matrix interference. Overall, the results provide a comprehensive framework for the rational design of MIP-based sensors targeting amphiphilic contaminants, supporting a transition from empirical optimization toward a more mechanistic understanding of molecular imprinting at electrochemical interfaces.

References

- [1] L. Wang, M. Pagett, & W. Zhang, *Sens. Actuat. Reports*, **2023**, 5, 100153.
- [2] M. S. Sengar, P. Kumari, N. Sengar, & S.K. Singh, *ACS Appl. Polym. Mater.*, **2024**, 6(2), 1086-1105.
- [3] N. Karimian, A.M. Stortini, L. M. Moretto, C. Costantino, S. Bogialli, & P. Ugo, *ACS Sensors*, **2018** 3(7), 1291-1298.

Acknowledgments: The research activities were supported by the European Union – Horizon Europe project ProCleanLakes (GA No. 101157886 – CUP H73C23001630006), carried out at the Department of Molecular Sciences and Nanosystems of Ca' Foscari University of Venice.